

NIKKI AC SERVO CONTROLLER

N E X S R T

N C S - F I 1 / 2 T Y P E

N C S - F S 1 / 2 T Y P E

< VOLUME:DEDICATED FUNCTION >

INSTRUCTION MANUAL

V e r . 1 . 1

NIKKI DENSO CO.,LTD.

Preface

Thank you for adopting Nikki Dedicated Function Control NC Servo Controller
< N E X S R T N C S - F I / F S series > .

【Notice of this manual】

This instruction manual explains about dedicated functions of Dedicated Function Control NC Servo Controller NCS-FI/FS 1 and NCS-FI/FS 2 types.

As for items of installation, wiring, operation, maintenance, trouble diagnosis, trouble shooting, etc. not described in this manual can be referred to the separate instruction manual 『Volume: Basic function』 .

As for description of sequence control section (Hereafter, 'SQB' is used) of NCS-FI/FS 2 types can be referred to the separate instruction manual 『Volume: SQB』 .

In order for you to use this unit properly, please deeply understand the contents of this manual.

If a unit with specific specification is used, please refer to this manual and specification sheet of the unit, altogether.
(The description of the specification sheet is prior to the same item in this manual.)

This manual is for the types which LCD display in Self-diagnostic display mode is as follows.

TYPE display : 「 FI 1m STD 」 , 「 FS 1m STD 」 ,
 「 FI 2m STD 」 , 「 FS 2m STD 」 ,

SOFT display: 「 1.02 」

【Warranty period】

Warranty period of our product is 1 year after shipping from our factory.
However please note that any failure or abnormality resulting from the following causes is not covered by our warranty.

Modification by parties other than NIKKI DENSO
None standard operation different from the description in our manual.
Natural disasters
Connection with an other maker's unit not approved by us.

When you find a failure or an abnormality during the warranty period, please contact our sales man.

When you receive the ordered units, please immediately check outlook of them and presence of accessories.

At unpacking if outlook of units is abnormal, non-specified accessories are found, or quantity is wrong, please do not use them and inform the results to our sales man.

NIKKI DENSO retains the right to revise this publication no matter how it is altered. Although the information from NIKKI DENSO is reliable, NIKKI DENSO will not assume responsibility whatever results may arise from the use of this information unless specially guaranteed by NIKKI DENSO.

Cautions for Safety

Before conducting installation, running, maintenance, and inspection, please deeply understand this manual, and all associated manuals / materials as well as the knowledge of all the applied equipment and information for safety and then use this unit properly.

In this manual, cautions for safety are ranked as 『Danger』 and 『Caution』 .
And cautions for handling are divided into 『Prohibition』 and 『Compulsion』 which are defined (Action not to be done) and (Action to be done.), respectively.



: If mis-handling is made, dangerous situation as death or serious injury could occur.



: If mis-handling is made, dangerous situation as medium or light injury and mechanical damage could occur.

However, (Caution) marked item could cause serious results depending on the actual situation. Since both of the above description include important contents, please be sure to follow them.



: **Prohibited action**
If this caution is ignored, this unit does not perform properly.



: **Compulsory action**
If this is ignored, this unit does not perform properly.

【 Cautions when using unit 】

 **Danger**

Since electric shock and injury may occur, please comply with the following suggestions.

Never touch inside of this unit (NC servo controller) and terminal blocks.

▮ **Electric shock may occur.** ▮

Be sure to make grounding of an earth terminal or lead wire of this unit (NC servo controller).

Use larger earth cables for JIS Class 3 or better grounding.

▮ **Electric shock may occur.** ▮

Transportation, wiring, maintenance, and inspection shall be conducted stipulated time after confirming complete lit off condition of front panel display, by power off.

▮ **Electric shock may occur.** ▮

Do not damage, force excessively, put on heavy thing, or nip cables.

▮ **Electric shock may occur.** ▮

Never touch rotating section of a running motor.

▮ **Injury may occur.** ▮

 **Caution**

Use specified motor and this unit (NC servo controller).

▮ **Fire or failure may occur.** ▮

Never use in the atmosphere such as water splash, corrosive or low flashing point gas and near flammable things.

▮ **Fire or failure may occur.** ▮

Since temperature of a motor, this unit (NC servo controller), and peripherals raises quite high, do not touch them.

▮ **Burn of a worker may occur.** ▮

In supplying power, or for a while after shutting power off, since a radiator, a regenerative unit, a motor etc. could be very hot, do not touch them.

▮ **Burn of a worker may occur.** ▮

【 Receiving and checking of packages 】

 **Caution**

When you receive ordered units, please check contents. if wrong thing is found or quantity is wrong, please do not use them and inform the status to our sales man.

▮ **Electric shock, injury, damage or failure may occur.** ▮

If packages of our products are broken, do not un-pack them and inform the fact to our sales man.

▮ **Electric shock, injury, damage or failure may occur.** ▮

【 Storage 】

 **Prohibition**

Do not store units in a place of raining, water dripping, and harmful gas /liquid.

Compulsion

Store units in a place of no sun-shine but controlled temperature / humidity within specified range.
If storage term became quite long, please consult purchased or nearest sales office before using them.

【 Transportation 】

Caution

Do not hold a cable and a motor shaft during transporting units.
▮ **Injury or failure may occur.** ▮

Compulsion

Comply with proper suggestion and avoid excess amount transportation which may break the whole package.

【 Installation 】

Caution

Do not climb or put any heavy thing on this unit.
▮ **Injury or failure may occur.** ▮
Do not disturb or choke intake / outlet air holes with foreign thing.
▮ **Fire may occur.** ▮
Use specified direction for installation.
▮ **Fire or failure may occur.** ▮
Keep specified distance between this unit and control panel inside or other equipment.
▮ **Fire or failure may occur.** ▮
Never apply heavy shock to this unit.
▮ **This unit may be damaged.** ▮
Conduct proper attachment suitable for the output or weight of this unit.
▮ **This unit may be damaged.** ▮
Attach this unit to non-flammable thing as metal.
▮ **Fire may occur.** ▮

【 Wiring 】

Caution

Be sure to conduct correct wiring.

▣ **Running away, burning of a motor, injury or fire may occur.** ▣

To prevent this unit from noise influence, use specified length treated (shielded / twisted, etc.) cables.

▣ **Running away of a motor, injury or machine damage may occur.** ▣

To prevent this unit (NC servo controller) from noise influence, use separate control I/O cables of the unit from other power cables.

▣ **Running away of a motor, injury or machine damage may occur.** ▣

To avoid electric shock and noise influence, be sure to make proper grounding (earthing).

▣ **Running away of a motor, electric shock, injury or machine damage may occur.** ▣

【 Operation · Run 】

Caution

There is no applicable protection to motors. For the protection, over-current protector, earth leakage breaker, over-heat protector, and emergency stop device shall be provided.

▣ **Injury or fire may occur.** ▣

Confirm that power source specification is correct.

▣ **Injury, fire or machine damage may occur.** ▣

At test run, fix a motor to a place separating from its machine system and confirm the motion, then connect the motor to the machine.

▣ **Injury or machine damage may occur.** ▣

Since the brake is only for holding machine position, do not use it for safety system of your machine.

▣ **Injury or machine damage may occur.** ▣

Since excess adjustment change may cause this unit unstable, avoid this situation.

▣ **Injury or machine damage may occur.** ▣

When an alarm occurs, eliminate the cause, reset the alarm and then resume this unit.

▣ **Injury or machine damage may occur.** ▣

When power recovers from black out status, since sudden restart may occur, do not approach the machine.

(Machine system design shall be considered to maintain safety of workers against the restart.)

▣ **Injury may occur.** ▣

Prohibition

Do not apply power in the motor turning or vibrating status.

▣ **Running away of a motor, injury or machine damage may occur.** ▣

Since the brake installed on a motor is only for holding, do not use it for actual braking.

Compulsion

Provide external shut down circuit in order to stop running and shut the power off, immediately.

【 Maintenance · Inspection 】

Caution

Capacity of condensers in the power line will be deteriorated.
To prevent secondary damage caused by condenser failure, we recommend to replace them for about every 5 years.

▮ **Failure may occur.** ▮

Cooling efficiency of a cooling motor will be deteriorated as time going.
To prevent secondary damage caused by condenser failure, we recommend to replace them for about every 5 years.

▮ **Failure may occur.** ▮

Prohibition

Overhaul / repair shall be conducted only by us or suggested shop.

Contents

	Page
Chapter 1 Outline	
1 - 1 Features	
1 - 1 - 1 NCS - FI / FS 1 type	1 - 1
1 - 1 - 2 NCS - FI / FS 2 type	1 - 3
1 - 2 System configuration	
1 - 2 - 1 NCS - FI / FS 10 type	1 - 4
1 - 2 - 2 NCS - FI / FS 12 type	1 - 5
1 - 2 - 3 NCS - FI / FS 13 type	1 - 6
1 - 2 - 4 NCS - FI / FS 22 type	1 - 7
1 - 2 - 5 NCS - FI / FS 23 type	1 - 8
1 - 3 Mode configuration	1 - 9
Chapter 2 Setting and display	
2 - 1 LCD module operation	
2 - 1 - 1 LCD module each component and function	2 - 1
2 - 1 - 2 LCD module operation procedure	2 - 3
2 - 2 Display mode	
2 - 2 - 1 Initial status display	2 - 5
2 - 2 - 2 Status display mode	2 - 6
2 - 2 - 3 Diagnosis display mode	2 - 8
2 - 3 Operation mode	
2 - 3 - 1 ITEM (Operation mode) list	2 - 11
2 - 3 - 2 Real time gain setting	2 - 13
Chapter 3 Parameter	
3 - 1 Parameter list	3 - 1
3 - 2 Parameter setting	3 - 4
3 - 3 Parameter specification	3 - 6
Chapter 4 Index data	
4 - 1 Index data list	4 - 1
4 - 2 Index data setting	4 - 3
4 - 3 Index data specification	4 - 5
Chapter 5 Command	
5 - 1 Command list	5 - 1
5 - 2 Command setting	5 - 4
5 - 3 Command specification	5 - 6
5 - 4 Driver command description	
5 - 4 - 1 【TRQ】Torque control	5 - 18
5 - 4 - 2 【SPD】Speed control	5 - 22
5 - 5 Driver command format	5 - 25

Chapter 6 Protective function

6 - 1 Protective function and error treatment ······ 6 - 1

6 - 2 Protective function list

6 - 2 - 1 Alarm list ······ 6 - 2

6 - 2 - 2 Warning list ······ 6 - 1 1

6 - 2 - 3 Error list ······ 6 - 1 2

Appendix

Ap. - 1 Input / Output signal list ······ Ap. - 1

Ap. - 2 Applicable motor list ······ Ap. - 3

Chapter 1 Outline

1 - 1 Feature

NCS-FI/FS of NCS-FI/FS 1 and NCS-FI/FS 2 (Hereafter, this unit or controller is used.) is corresponding to the following 2 types which function and operation are identical.

NCS-FI 1 and 2 type : AC servo controller for induction AC servo motor

NCS-FS 1 and 2 type : AC servo controller for synchronous AC servo motor

1 - 1 - 1 NCS-FI/FS type

<NEXSRT NCS-FI/FS 1 type> is an integrated 『NC servo controller』 consists of AC servo driver and 1 axis positioning unit for general purpose and multiple functions.

This unit has several following features suitable for positioning control of various industrial machines.

【NCS-FI/FS type features】

By combining 1 axis positioning unit with AC servo driver, less wiring system and compact size were realized.

Full digital control achieved less temperature drift, fine adjustment, strengthened Man-machine interface, etc., seeking for better reliability and easier operation.

The custom made LCD module supports each Monitoring, Alarm history record, Self-diagnostic function, etc.. And reliability and maintenance method are improved.

Many custom made LSIs and less wiring structure improved reliability and realized compact size of this unit.

Adoption of IPM (IGBT) in the power switching section, improved servo performance and lowered noise.

Either Positioning run, or Pulse train run mode can be selected for wide range of application requirements.

Program run by internally stored data (280 points) can be conducted.

External trigger positioning can be conducted.

Position data and speed data can be set by Index data.

Control such as Linear / S shape curve Accel./ Decel., Feed-forward, Torque command filter, gain change at stop status or Decel., R2 compensation, Non-coherence control, etc. can be conducted by advanced software servo suitable for machine rigidity.

By setting a parameter, one unit can be available for various AC servo motor types.

By setting a parameter, "full closed loop control" by feedback pulses using measuring encoder output can be conducted.

Through Serial communication, peripheral as a touch panel, main computer, MDI, servo display, etc. can be interfaced.

Zero return is not necessary by using an optional absolute encoder.

Auto. tuning function

Torque control and Speed control can be conducted by commands.

Pulse train run of max. 10 axes synchronized to a command value can be conducted.

Either induction servo motor or synchronous servo motor can be controlled by same operation.

【NCS-FI/FS 1 types】

NCS-FI/FS 10 : It controls with internally stored data by commands from a main controller.

I/O points 「Input : 28 points output : 8 points」

NCS-FI/FS 12 : It controls with internally stored data by commands from a main controller.

I/O points 「Input : 37 points output : 18 points」

NCS-FI/FS 13 : It controls with internally stored data controlled by remote sequence.

Remote sequence control is the control of NCS-FI/FS 23, NCS-FI/FS 13, and Remote I/O unit connected by high speed communication as the control of Input / Output directly connected by sequence control of NCS-FI/FS 23.

1 - 1 - 2 NCS - FI / FS 2 type

<NEXSRT NCS-FI/FS 2 type> is a version of NCS-FI/FS 1 types combined with sequence function and an 『Integrated controller』 consists of 3 major functions, Power control, NC, and Sequence control.
In addition to the features of FI/FS 1 type, below advantages are added which realizes **integrated control** of various industrial machines.

【NCS-FI/FS 2 type features】

Exclusive management of System control is possible.

More compact size, less wiring, and simpler operation of the unit are realized.

Exclusive management of data related both to NC control section and Sequence control section can be conducted.

By mutual monitoring function of NC control section and Sequence control section, reliability is improved.

Cost performance to a function is raised.

Creation, edition, and transmission of Sequence program are conducted by a main personal computer with a dedicated software and those data are stored in the unit. The program language supports mnemonic method and ladder method.

Data (position, speed , etc.) for Auto. run of NC control section can be stored as sequence data.

Machine status monitoring can be conducted by LCD of NC control section and next display units.

- Touch panel
- LED of Sequence control (I/O status display)
- Main computer

By parameter setting, Read / Write of NC control section data can be freely conducted in Sequence program.

Sequence control of max. 16 axes can be conducted by one controller with sequence control function.

【NCS-FI/FS 2 types】

Number of external I/O for Sequence control of NCS-FI/FS 2 are as follows.

NCS-FI/FS 22 : 「 Input : 64 points output : 32 points 」

NCS-FI/FS 23 : 「 Input : 64 points output : 32 points,

By combination of NCS-FI/FS13 and a remote I/O unit, max. 15 units can be connected. 」

1 - 2 System configuration

1 - 2 - 1 NCS-FI/FS10 type

Peripheral system configuration of NCS-FI/FS 10 unit is as [Fig.1 - 1] .

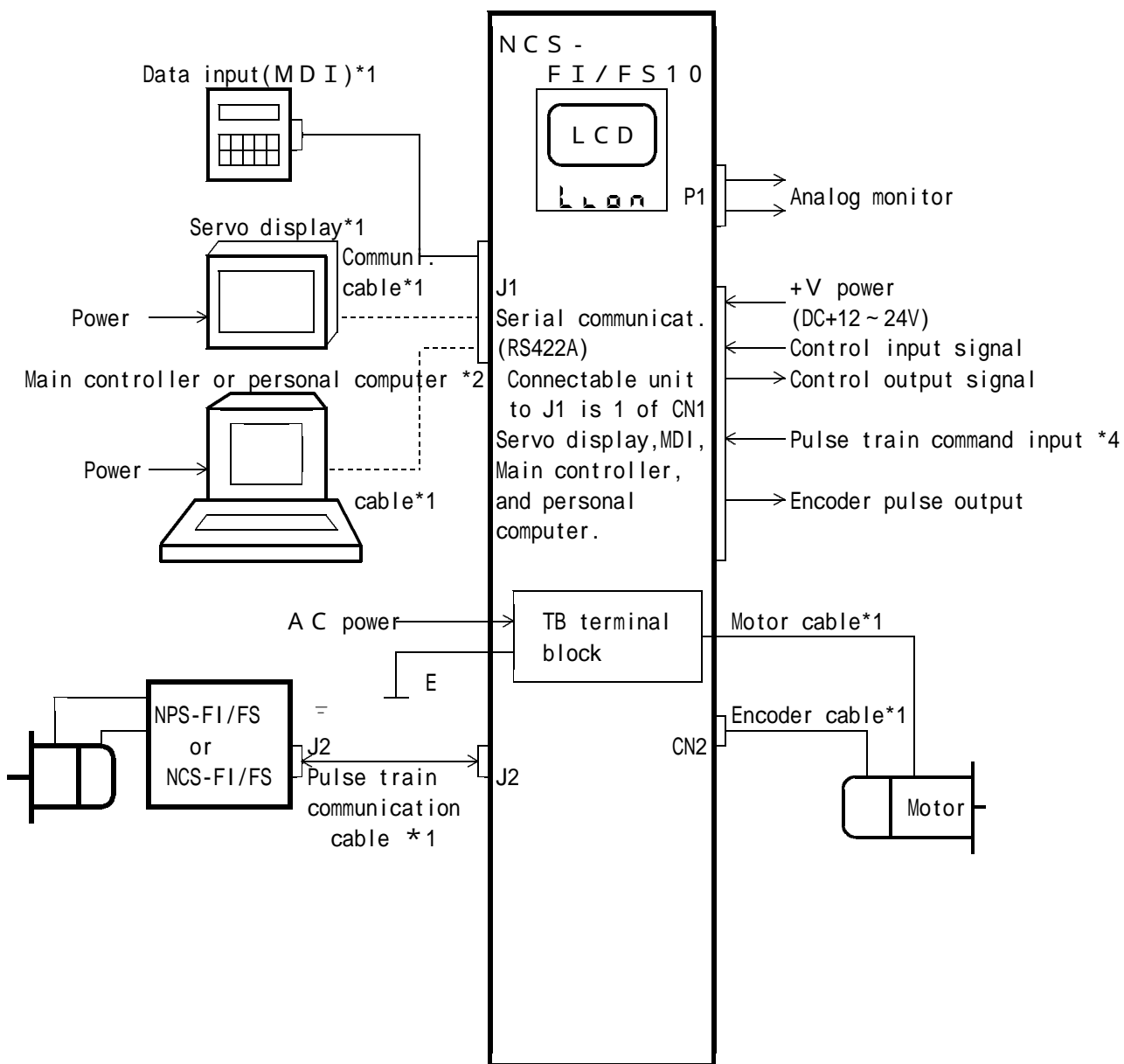

[Fig.1 - 1] NCS-FI/FS10 type system configuration

Caution 1: Our optional unit is available for the item with *1 mark.
 Please use an unit on the general market for the item with *2 mark.
 NPS-FI/FS with *3 mark is a controller for Speed control, Torque control, and Pulse train control.
 The item with mark *4 can be changed to feedback pulse input from a measuring encoder by parameter setting which enables full closed loop control.

1.

Caution 2: Our optional "Data edit software for a personal computer" can be available.

1 - 2 - 2 NCS-FI/FS12 type

Peripheral system configuration of NCS-FI/FS 12 unit is as [Fig. 1 - 2] .

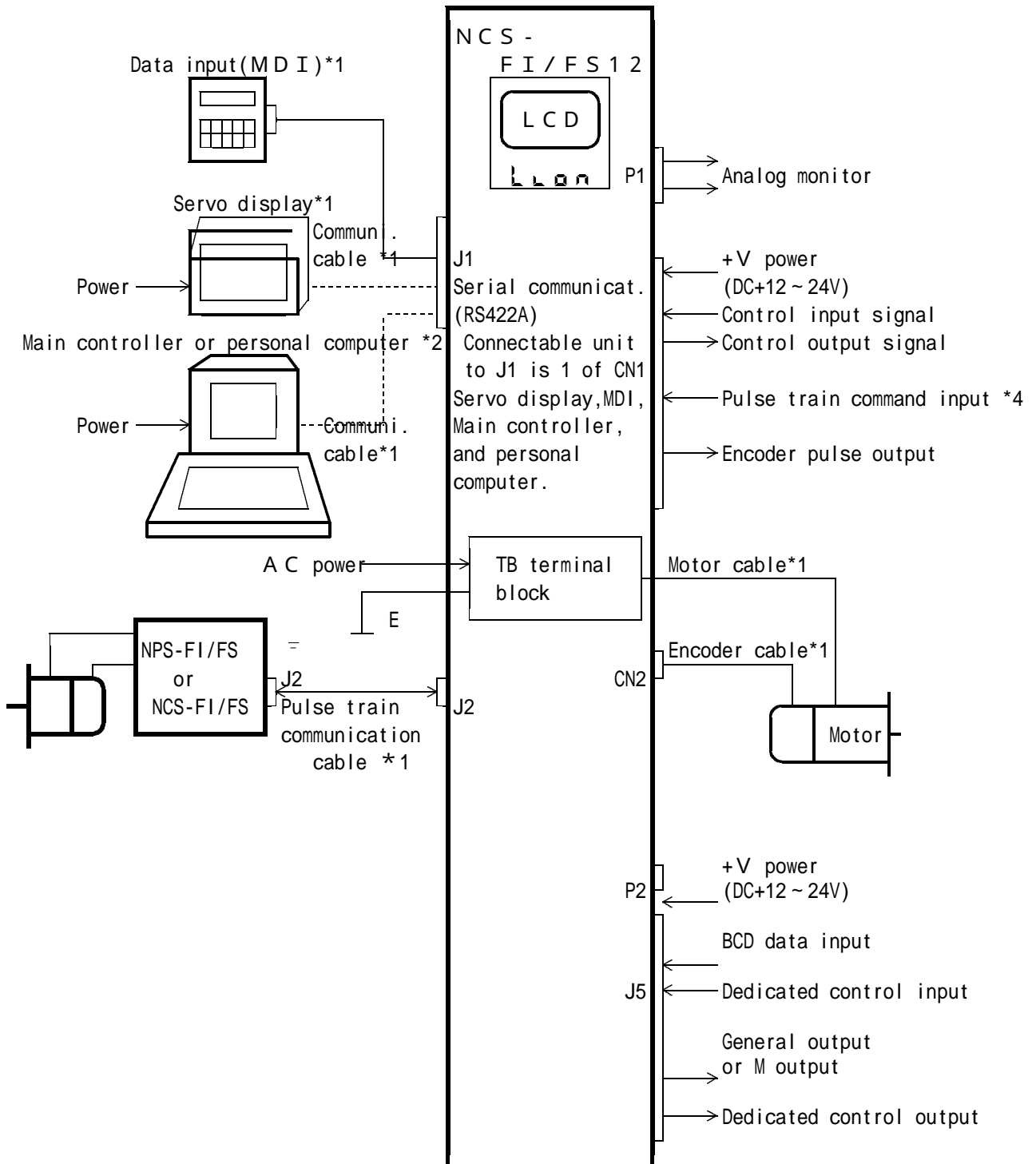

[Fig. 1 - 2] NCS-FI/FS12 type system configuration

Caution 1 : Our optional unit is available for the item with *1 mark.
 Please use an unit on the general market for the item with *2 mark.
 NPS-FI/FS with *3 mark is a controller for Speed control, Torque control, and Pulse train control.
 The item with mark *4 can be changed to feedback pulse input from a measuring encoder by parameter setting which enables full closed loop control.

Caution 2 : Our optional "Data edit software for a personal computer" can be available.

1 - 2 - 3 NCS-FI/FS13 type

Peripheral system configuration of NCS-FI/FS 13 unit is as [Fig. 1 - 3] .

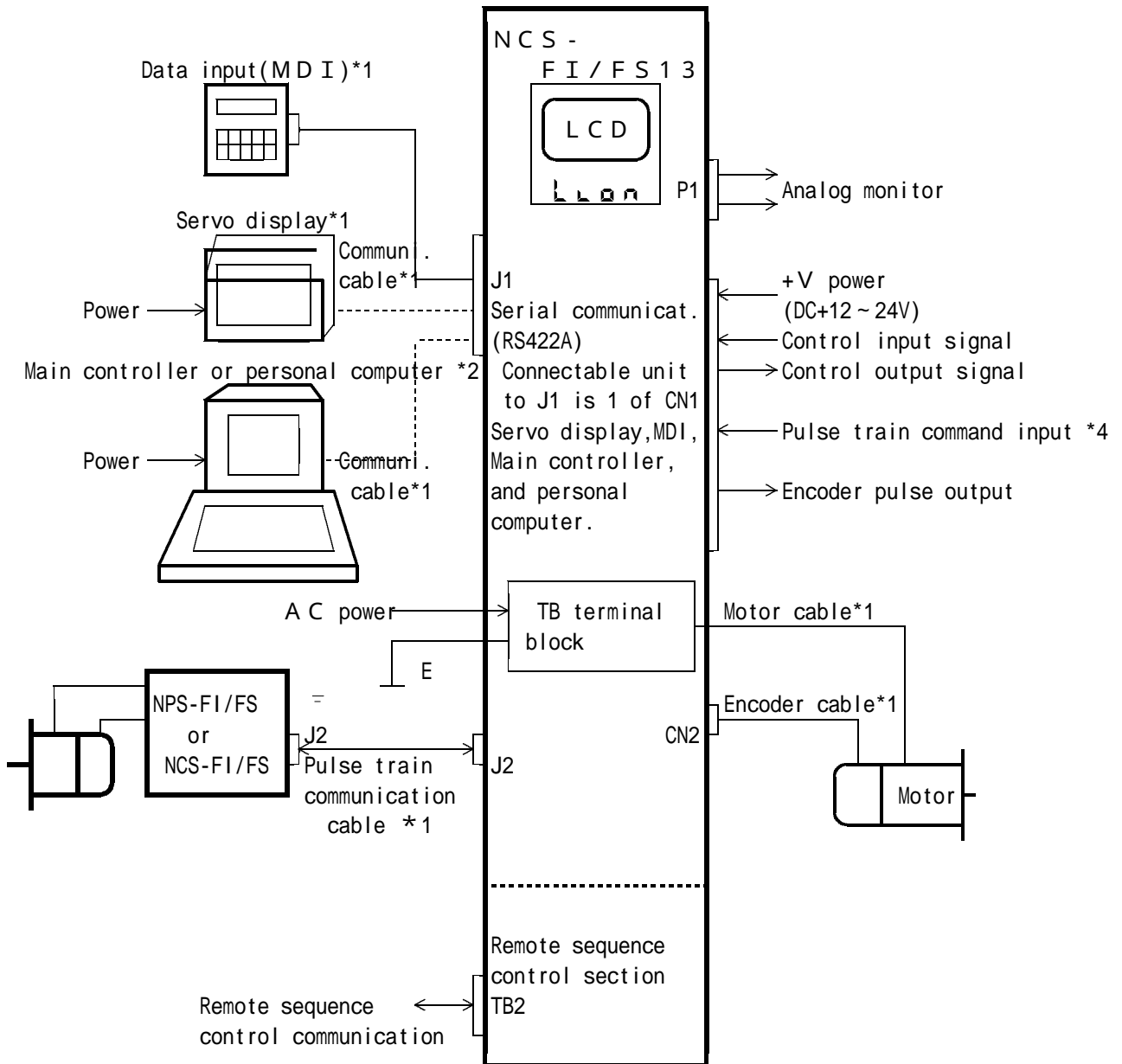

[Fig. 1 - 3] NCS-FI/FS13 type system configuration

Caution 1 : Our optional unit is available for the item with *1 mark.
Please use an unit on the general market for the item with *2 mark.
NPS-FI/FS with *3 mark is a controller for Speed control, Torque control, and Pulse train control.
The item with mark *4 can be changed to feedback pulse input from a measuring encoder by parameter setting which enables full closed loop control.

Caution 2 : Our optional "Data edit software for a personal computer" can be available.

1 - 2 - 4 NCS-FI/FS22 type

Peripheral system configuration of NCS-FI/FS 22 unit is as [Fig. 1 - 4].

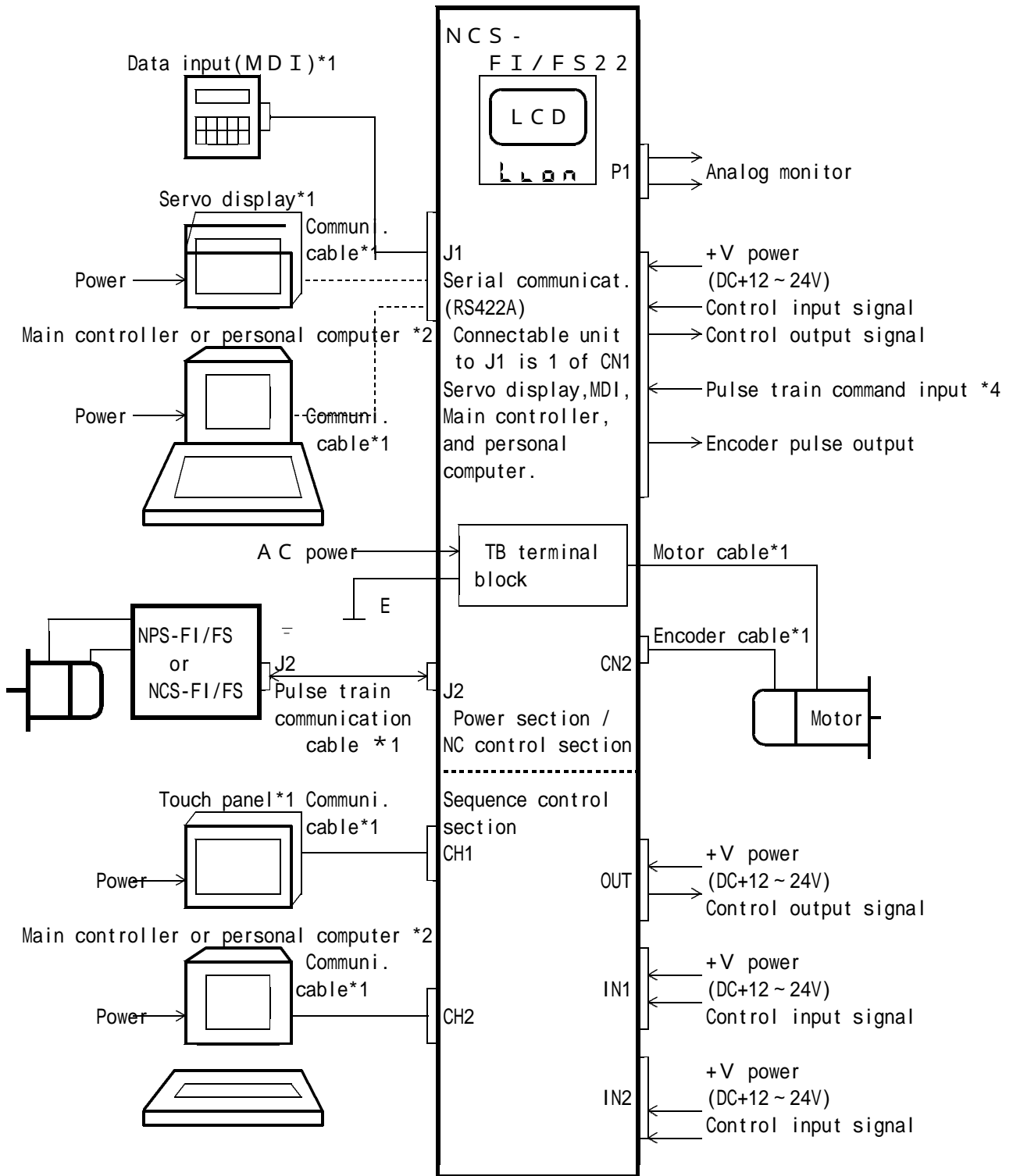

[Fig. 1 - 4] NCS-FI/FS22 type system configuration

Caution 1 : Our optional unit is available for the item with *1 mark.
 Please use an unit on the general market for the item with *2 mark.
 NPS-FI/FS with *3 mark is a controller for Speed control, Torque control, and Pulse train control.
 The item with mark *4 can be changed to feedback pulse input from a measuring encoder by parameter setting which enables full closed loop control.

Caution 2 : Our optional "Data edit software for a personal computer" can be available.

1 - 2 - 5 NCS-FI/FS23 type

Peripheral system configuration of NCS-FI/FS 23 unit is as [Fig. 1 - 5].

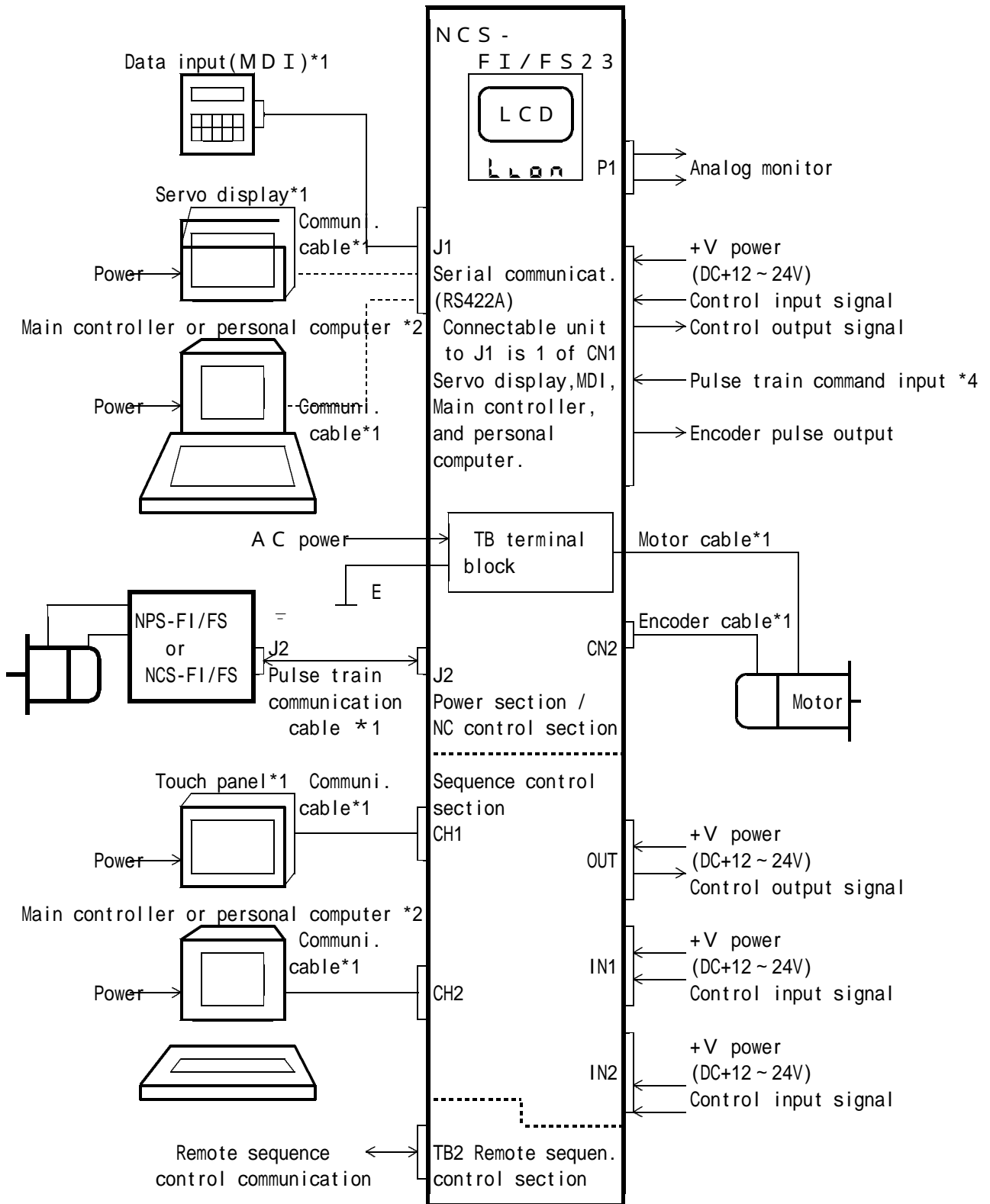

[Fig. 1 - 5] NCS-FI/FS23 type system configuration

Caution 1: Our optional unit is available for the item with *1 mark.
 Please use an unit on the general market for the item with *2 mark.
 NPS-FI/FS with *3 mark is a controller for Speed control, Torque control, and Pulse train control.
 The item with mark *4 can be changed to feedback pulse input from a measuring encoder by parameter setting which enables full closed loop control.

Caution 2: Our optional "Data edit software for a personal computer" can be available.

1 - 3 Mode configuration

[1] Run mode

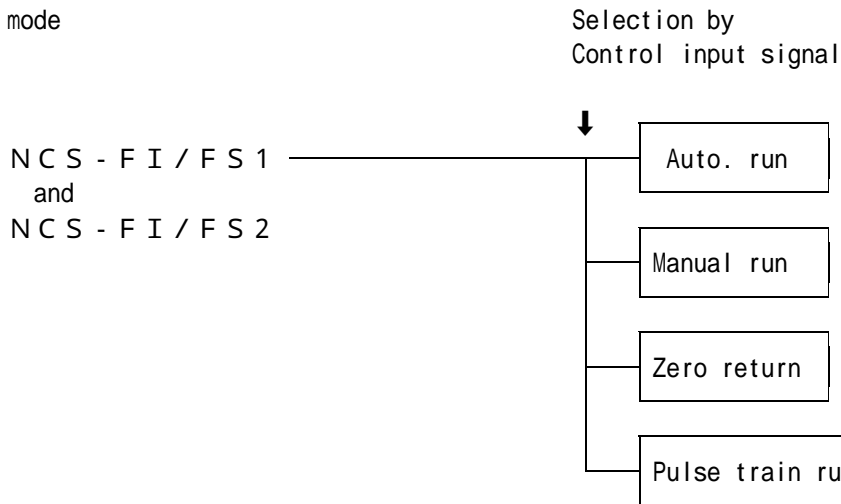

And there are modes which change the condition to enable External input signal or Remote input signal by Control input signal as follows. (Change by Control input signal 「PC」.)

- * Local mode : Control as individual Run mode selection, Motion start / stop, etc. is conducted in Local run by an effective Control input signal in accordance with External input disable selection parameters (P516,P518).
- * Remote mode : Control as individual Run mode selection, Motion start / stop, etc. is conducted in Remote run by an effective Control input signal in accordance with External input disable selection parameters (P517,P519).

And Remote input signal is the interface to conduct control as External input signal of a controller by using Serial communication or Sequence control section.

[2] Operation mode

Operation block figure by LCD section or MDI

Selection by MOD key

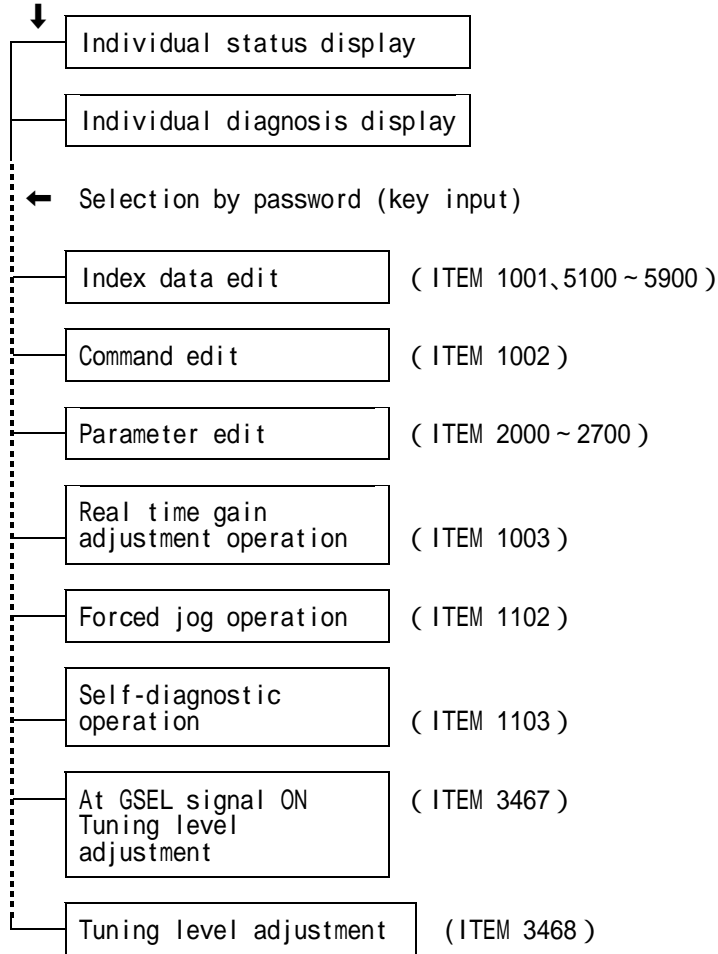

Chapter 2 Setting and display

2 - 1 L C D module operation

2 - 1 - 1 L C D module each component function

Various parameters and data are set by key input of L C D module in the controller front panel.

Since parameters deeply influence motion of machine system and whole system, pay special attention to set.

[1] L C D module outlook

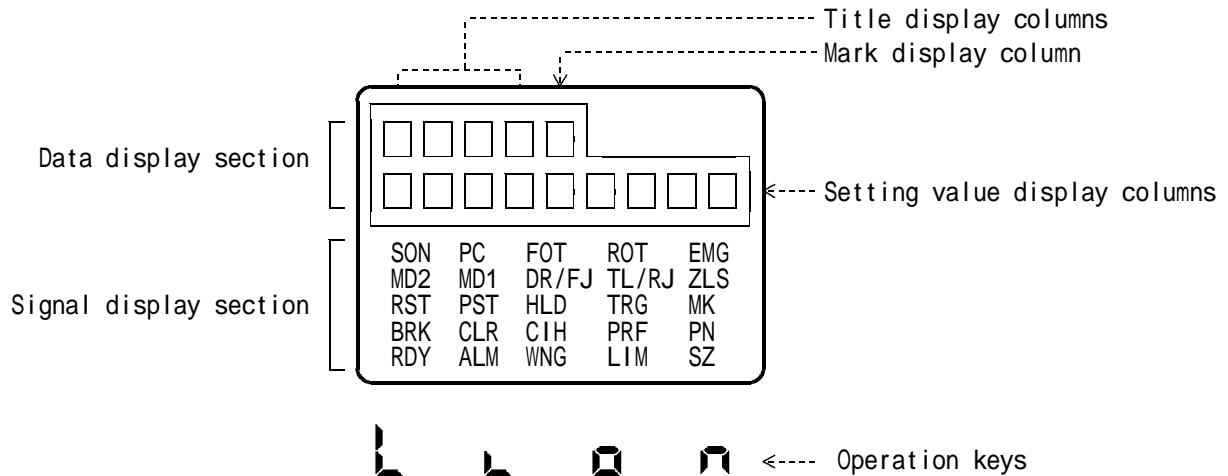

[Fig. 2 - 1] L C D module outlook

[2] Display contents of each display section

Display section		Display contents
Data display section	Title display columns	Subject item title (name, No.), message (Alarm, /WNG, /Error), etc. when Protective function works, are displayed.
	Mark display column	Contents as mark, etc. of subject item data are displayed. 「P」 indicates positive direct data. 「-」 indicates negative direct data. 「*」 indicates Index data set. 「/」 indicates setting data are invalid.
	Setting value display column	Subject item data (setting value / status / Diagnosis results / Alarm name, etc.) are displayed.
Signal display section		I/O signal status is displayed. When a signal is inputted or outputted, corresponding letter is lit. Details can be referred to the separate manual 『Volume: Basic function』.

[Tab. 2 - 1] Display contents of each display section

[3] Each operation key function

Key	Function	
L	Item select.	Displays next item.
	Data setting	Increases number (0~9), change of (P , - , * , /) mark and displays next data value of menu data.
L	Item select.	Displays back item.
	Data setting	Decreases number (0~9), change of (P , - , * , /) mark and displays back data value of menu data.
D	Item select.	Displays top item of next subject mode.
	Data setting	Selects data setting columns.
n	Item select.	Moves to data setting status of subject item.
	Data setting	Enters display data (all columns) as new data.
LL	At Power ON	Initializes all the stored data. Refer to the following caution.
	Data setting	Finishes data setting, forcibly. (Data are not changed, and back data are retained.)
L on	Full time	Resets CPU by simultaneously pushing them for 3 sec.. 【Caution】 In case of NCS-FS type, since 「Encoder fault」 occurs by CPU fault, it can not be used. It is not accepted in Self-diagnostic or HALT.

[Tab. 2 - 2] Each operation key function

【Caution】

When unit power is ON by pushing L and L keys, simultaneously, all the stored data (parameter , etc.) are initialized.

And then, following figure is displayed in LCD data display section.

INIT DATA

We recommend you to save data before initializing the unit.

Backup of data by a personal computer can be conducted by our optional Data edit software.

2 - 1 - 2 LCD module operation procedure

Display & key operation and data setting flow chart is shown as below.

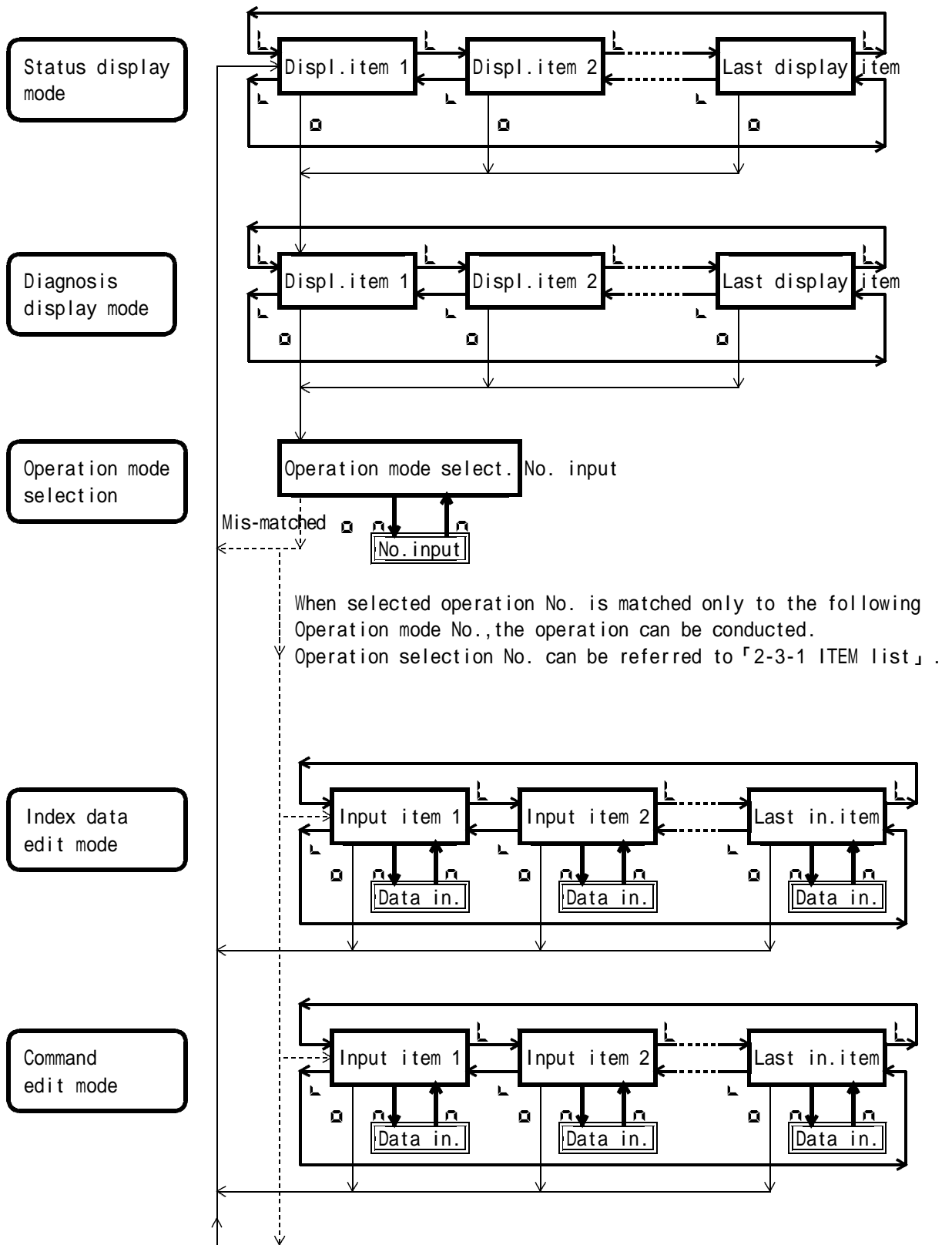

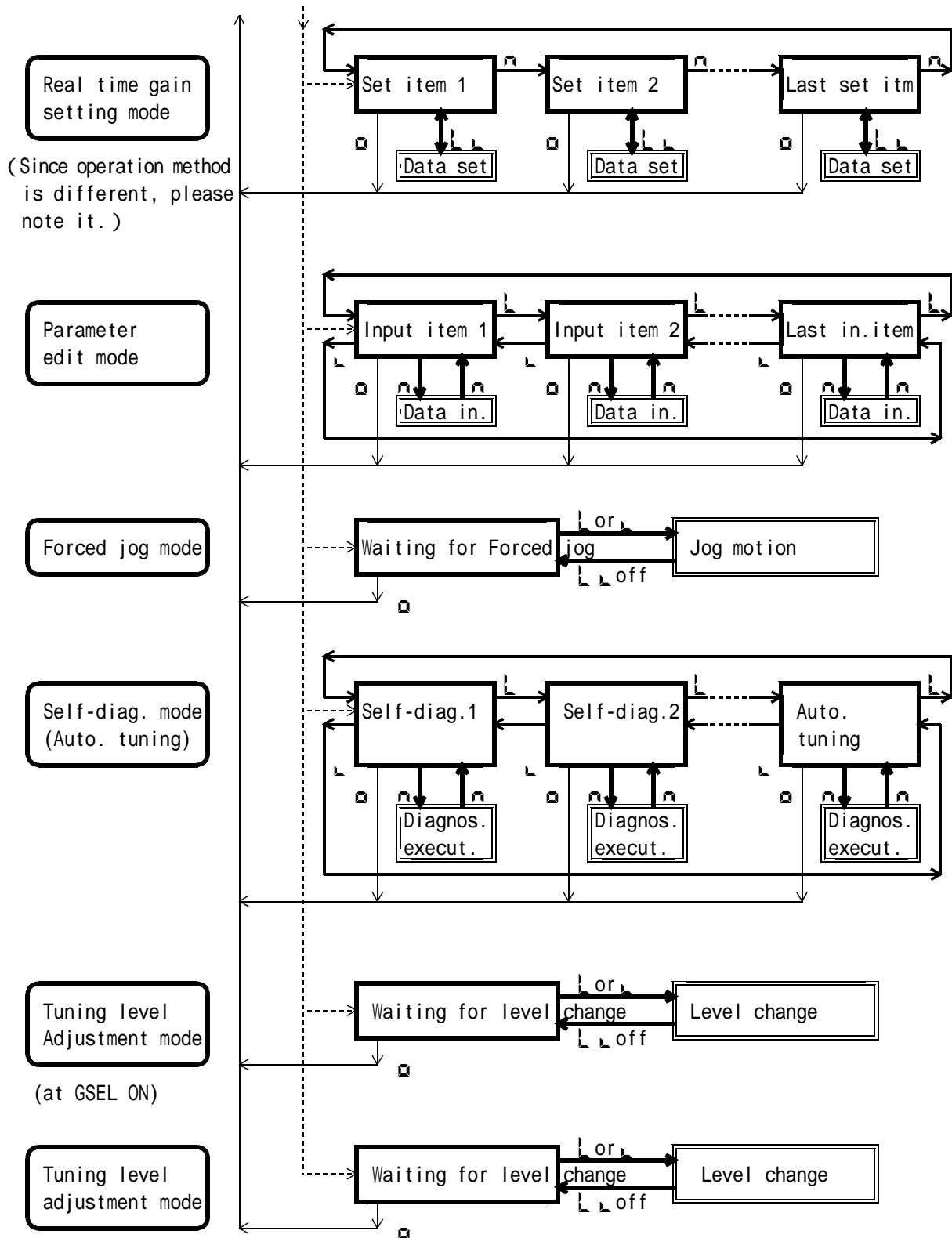

[Fig. 2 - 2] Display & key operation flow chart

2 - 2 Display mode

2 - 2 - 1 Initial status Display

- ⚠ During an unit is initialized when power source is turned ON, 『Power ON!』 is displayed.
- ⚠ At the unit shipment, initial values are set to various parameters and data.
- ⚠ Since a motor not selected by the parameter P000 can not run, at first [P000: Motor type selection] and other parameter shall be set to meet the applied conditions.
- ⚠ In order to confirm parameters and request resetting, soon after power source is turned ON for the first time, Motor not selected alarm 『ALM MOTOR TYPE1』 is displayed.
- ⚠ Simultaneously, Alarm signal is outputted.
- ⚠ Initial status display can be cleared by any of \downarrow / \leftarrow / \rightarrow / \uparrow key input.
- ⚠ After display is cleared, contents can be confirmed by Alarm history.



[Fig. 2 - 3] Initial status display

Display sample

《Motor torque is displayed.》

Actual torque is displayed in Status display (S T 1 0).

- 1) By \rightarrow , display mode changes in turns as Status display (S T 0 0) Diagnosis display (T Y P E) Operation selection (I T E M) Status display (S T 0 0)
Select Status display mode (S T 0 0) .
- 2) By \leftarrow , Display item changes in turns as (S T 0 0) (S T 0 1)
Select display item (S T 1 0) .
- 3) Selected data of (S T 1 0) displays running motor torque.

《Alarm status is confirmed.》

When Alarm occurs. Alarm contents are displayed in Diagnosis display (A L M 0) .

- 1) By \rightarrow , display mode changes in turns as Status display (S T 0 0) Diagnosis display (T Y P E) Operation selection (I T E M) Status display (S T 0 0)
Select Diagnosis display mode (T Y P E) .
- 2) By \leftarrow , Display item changes in turns as (T Y P E) (M O D E)
Select display item (A L M 0) .
- 3) Selected data of (A L M 0) displays activated Alarm contents.

2 - 2 - 2 Status display mode

△ In Title display columns, status (STxx), in Setting value display columns, status data, and in Mark display column, a mark are displayed.

Dsp. No.	Display sample	Unit	Display Contents
1		rpm	Displays actual motor speed. In forward run: P, In reverse run: - Display range : -9999 ~ 9999
2		1	Displays current position. Display contents can be set by [P502 : Current posi. display selection]. Display range : -99999999 ~ 99999999 2
3		Pls.	Displays Position deviation pulse. + deviation : P, - deviation : - Display range : -32767 ~ 32767
4		rpm	Displays External speed command input value by rpm. Forward cmmd. : P, Reverse cmmd. : - Display range : -99999 ~ 99999
5		%	Displays External torque command input value by % to rated torque. Forward cmmd. : P, Reverse cmmd. : - Display range : -300 ~ 300
6		Kpps	Displays Pulse train command input frequency Forward cmmd. : P, Reverse cmmd. : - Display range : -500.00 ~ 500.00
7		Pls.	Displays accumulated input pulse numbers of Pulse train command. Forward cmmd. : P, Reverse cmmd. : - Display rang : -99999999 ~ 99999999
8		%	Displays Forward torque limit command input value by % to rated torque. Display range : 0 ~ 300
9		%	Displays Reverse torque limit torque. Display range : 0 ~ 300
10		%	Displays thermal trip ratio by %. Display range : 0 ~ 100 When display exceeds 90 (90%), Overload warning and 100 (100%), Overload alarm occurs.

[Tab. 2 - 3 (a)] Display contents of Status display mode 1/2

△ In this display mode, if \blacktriangleleft key is pushed once, display data are retained for 1 second, and continuously pushed, display is retained.

1 : Unit can be set one of 「mm」, 「°」, and 「in(inch)」 by the parameter [P301].

2 : The decimal point location is set by the parameter [P302].

Dsp. No.	Display sample	Unit	Display Contents
1 1		%	Displays actual Torque command by % to rated torque. Display range : 0 ~ 300
1 2		%	Displays peak Torque command by % to rated torque. (RST signal becomes 「000」.) Display range : 0 ~ 300
1 3		rpm	Displays actual speed of a turning work. Forward cmmd. : P, Reverse cmmd. : - Display range : -9999 ~ 9999
1 4		1	Displays actual speed of a machine. Forward cmmd. : P, Reverse cmmd. : - Display range : -9999999 ~ 9999999 2

[Tab. 2 - 3 (b)] Display contents of Status display mode 2/2

△ In this display mode, if Δ key is pushed once, display data are retained for 1 second, and continuously pushed, display is retained.

1 : Unit can be set one of 「mm」, 「°」, and 「in(inch)」 by the parameter [P301].

2 : The decimal point location is set by the parameter [P302].

2 - 2 - 3 Diagnosis display mode

△In data display section, message and data are displayed.

Dsp. NO.	Display sample	Unit	Display Contents
1		—	Displays name of NCS-FI/FS series. Display sample : N C S - F I 1
2		—	Displays selection status of Remote / Local change (PC) signal for control signal. Display sample : Local mode
3		—	Displays execution of Auto. run start, or executing address and its command. Display sample : POS command (Positioning command)
4		1	Displays Jog speed selected by Jog speed change signal Display range : 0 ~ 9999999 2
5		%	Displays Speed override signal input status by Override ratio (%). Display range : 0 ~ 150
6		—	Displays status of External input signals SS1~3, PS4~8.(1:ON / 0:OFF) Status of Input signals SS1~3, PS4~8 at input signal allocation can be confirmed. Display sample : SS1 and3 ON, PS6 and7 ON, others OFF
7		—	Displays status of External input signals OR1~4 (1:ON / 0:OFF) Status of Input signals OR1~4 at input signal allocation can be confirmed. Display sample : OR2 and 3 ON, others OFF
8		—	Displays status of External output signals which can be allocated to output signals. (1:ON / 0:OFF) Output signal status at output signal allocation can be confirmed. Display sample : PN,PRF and LIM ON, others OFF

[Tab. 2 - 4 (a)] Display contents of Diagnosis display mode 1/3

1 : Unit can be set one of 「mm」 , 「 ° 」 ,and 「in(inch)」 by the parameter [P301].

2 : The decimal point location is set by the parameter [P302] .

Dsp. No.	Display sample	Unit	Display Contents
9	ALM0 IPM ERR.	—	Displays latest Alarm contents. Display sample : IPM fault
10	ALM1 ENCODER	—	Displays one time old Alarm contents. Display sample : Encoder fault
11	ALM2 OVERLOAD	—	Displays 2 times old Alarm contents. Display sample : Over load error
12	ALM3 OVERVOLT	—	Displays 3 times old Alarm contents. Display sample : Over voltage error
13	ALM4 OVERSPEED	—	Displays 4 times old Alarm contents. Display sample : Over speed error
14	WNG0 OVERLOAD	—	Displays latest Warning contents. Display sample : Over load warning
15 3	SQB STNo. 6203	—	Displays SQB status information. 4 Display range : 0 ~ 9999 Display sample : 「Sum check error」 occurs.
16 3	SQB Ver 1.00	—	Displays SQB software version. Max. display : 9.99

[Tab. 2 - 4 (b)] Display contents of Diagnosis display mode 2/3

3 : NCS-FI/FS 10 and 12 types do not display.

4 : SQB status information can be referred to the separate manual 『Volume: SQB』.

Dsp. No.	Display sample	Unit	Display Contents
175		—	<p>Displays an output to J5 connector or M output. (1:ON / 0:OFF)</p> <p>Display sample : In case of output, OUT1,OUT3 and OUT6 ON others OFF In case of M output, 25</p>
185		—	<p>Displays M strobe output and M complete input of J5 connector. (1:ON / 0:OFF)</p> <p>Display sample : MFIN ON, others OFF</p>
19		—	<p>Displays hardware version.</p> <p>Max. display : 9.99</p>
20		—	<p>Displays software version.</p> <p>Max. display : 9.99</p>

[Tab. 2 - 4 (c)] Display contents of Diagnosis display mode 3/3

5 : NCS-FI/FS 10, 13, 22, and 23 types do not display.

2 - 3 Operation mode

2 - 3 - 1 ITEM (Operation mode) list

Selection ITEM (Operation mode) is shown in Tab. 2 - 5 .

ITEM Select.No.	Operation mode		
1 0 0 1	Index data edit mode (I X 0 0 ~ I X 9 9)		
1 0 0 2	Command edit mode		
1 0 0 3	Real time gain set mode		
1 1 0 2	Forced jog mode (Refer to separate manual 『Volume: Basic function』).		
1 1 0 3	Self-diag. mode (Refer to separate manual 『Volume: Basic function』).		
2 0 0 0	Group 0	Motor, encoder parameter	Parameter edit mode
2 1 0 0	Group 1	Driver adjustment parameter	
2 2 0 0	Group 2	N C adjustment parameter	
2 3 0 0	Group 3	Position adjustment parameter	
2 4 0 0	Group 4	Run motion parameter	
2 5 0 0	Group 5	Display,edit,communi.,parameter	
2 6 0 0	Group 6	Pulse train input parameter	
2 7 0 0	Group 7	I/O signal parameter	
5 1 0 0	I X 1 0 0 ~ I X 1 9 9		Index data edit mode
5 2 0 0	I X 2 0 0 ~ I X 2 9 9		
5 3 0 0	I X 3 0 0 ~ I X 3 9 9		
5 4 0 0	I X 4 0 0 ~ I X 4 9 9		
5 5 0 0	I X 5 0 0 ~ I X 5 9 9		
5 6 0 0	I X 6 0 0 ~ I X 6 9 9		
5 7 0 0	I X 7 0 0 ~ I X 7 9 9		
5 8 0 0	I X 8 0 0 ~ I X 8 9 9		
5 9 0 0	I X 9 0 0 ~ I X 9 9 9		
3 4 6 7	Auto. tuning level adjustment mode (At GSEL signal ON) (Refer to separate manual 『Volume: Basic function』)		
3 4 6 8	Auto. tuning level adjustment mode (Refer to separate manual 『Volume: Basic function』)		

[Tab. 2 - 5] ITEM (Operation mode) list

Display sample

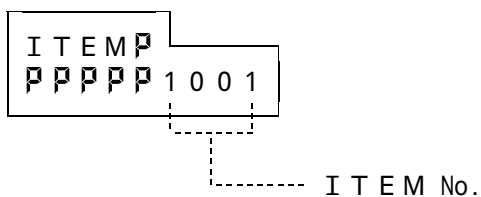

Setting

① ITEM No. input 1

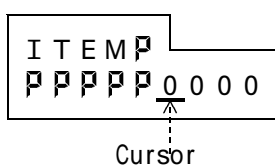

⚠ When key is pushed, a cursor appears and input can be conducted.

⚠ When or key is pushed, numeric value or mark changes.

⚠ When key is pushed, a cursor moves.

⚠ To cancel input data, push keys, together.

② ITEM No. input 2

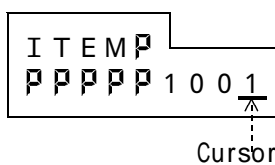

⚠ By the above operation, input ITEM No. 「Sample : 1001」.

③ ITEM No. setting

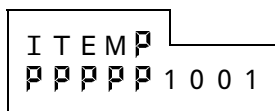

⚠ When key is pushed, a cursor disappears and ITEM No. is set.

2 - 3 - 2 Real time gain setting

[1] Function

Real time gain setting adjusts various unit gains in the dedicated mode in 'Real time', watching motor motion status.

In parameter edit mode, when Δ key is pushed, new gain works on actual motion but in Real time gain setting mode, when \downarrow or \uparrow key is pushed, ± 1 step of gain changes and new gain immediately works on actual motion.

[2] Setting method

Parameters for Real time gain setting are shown in Tab. 2 - 6 .

Para.	Parameter name	Initial value
p 1 0 1	Speed loop gain	0 2 5
p 1 0 2	Speed loop integral time constant	0 2 0 [ms]
p 1 0 4	Torque command filter frequency	0 0 0 [Hz]
p 1 0 5	Speed loop gain / Low speed gain range	0 2 5
p 1 0 6	Speed loop integral time constant / Low speed gain range	0 2 0 [ms]
p 1 0 8	Torque command filter frequency / Low speed gain range	0 0 0 [Hz]
p 1 1 6	Speed loop gain / at GSEL signal ON	0 2 5
p 1 1 7	Speed loop integral time constant / at GSEL signal ON	0 2 0 [ms]
p 1 1 8	Torque command filter frequency / at GSEL signal ON	0 0 0 [Hz]
p 2 0 0	Position loop gain	0 2 0 [1/S]
p 2 0 1	Servo lock gain	0 2 0 [1/S]

[Tab. 2 - 6] Real time gain setting parameter

ITEM Δ 1 0 0 3 (Selection of Real time gain setting mode) Δ \square

p * * * Δ (Selection of setting parameter)

!----- * mark is parameter (Refer to Tab. 2 - 6.)

Data setting of a selected parameter (gain adjustment)

+1 is added every time when \downarrow key is pushed once.

-1 is deducted every time when \uparrow key is pushed once.

When \square key is pushed, this mode is escaped.

(At the time display becomes 「Status display mode」.)

Display sample

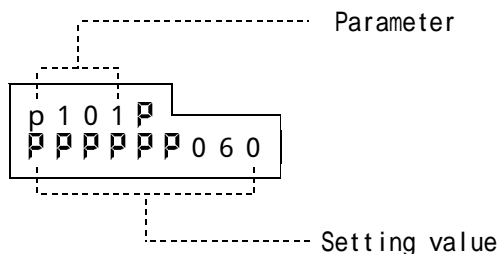

In the display, in order to identify same item of Parameter edit mode, at the top of parameter, small letter 'p' is used.

【Caution!!】

Though the gain value in setting, immediately works on actual motion, it is not written to backup memory. Write of setting data is conducted when Δ or \square key is pushed.

Chapter 3 Parameter

3 - 1 Parameter list

No.	Name
P000	Motor type
P001	Encoder type selection
P002	Encoder pulse selection
P004	Encoder pulse output division value
P005	ABS encoder resolution selection
P006	ABS reference data
P007	ABS reference machine position
P008	Carrier frequency selection
P020	Motor type · Number of poles
P021	Rated torque current
P022	Rated spd.(Field control base spd.)
P023	Max. transit torque ratio
P024	Number of exciting current
P026	Current loop coefficient
P028	R2 compensation change ratio
P030	Phase compensation angle
P037	Torque cmmnd.change limiter value
P040	Primary resistor
P041	Secondary resistor
P042	Primary self inductance
P043	Secondary self inductance
P044	Mutual inductance
P045	Leakage coefficient
P046	Dead time compensation time
P047	Current loop cut of frequency
P048	Current loop derivative time const.
P049	Torque constant
P059	Special encoder pulse number

No.	Name
P100	Low speed gain range
P101	Speed loop gain
P102	Speed loop integral time constant
P103	Speed loop derivative time constant
P104	Torque command filter frequency
P105	Speed loop gain / Low speed gain
P106	Speed loop integral time constant / Low speed gain
P107	Speed loop derivative time constant / Low speed gain
P108	Torque command filter frequency / Low speed gain
P109	Torque limit value 1 +
P110	Torque limit value 1 -
P111	Torque limit value 2 +
P112	Torque limit value 2 -
P113	Auto.tuning trial run direct.selec.
P114	Auto.tuning trial run speed ratio
P115	Torque limit select.at Alarm stop
P116	Speed loop gain / at GSEL signal ON
P117	Speed loop integral time constant / at GSEL signal ON
P118	Speed loop derivative time constant / at GSEL signal ON
P119	Torque command filter frequency / at GSEL signal ON
P120	R2 compensation selection
P121	Elect. thermal detection selection
P122	Non-coherence control Enable / Disable selection
P124	Speed command gain
P125	Speed command off-set
P126	Torque command off-set
P127	External speed limit Enable / Disable selection
P128	Speed limit value
P129	Spd.cmmnd.val.1(In Spd.cntrl.cmmnd.)
P130	Spd.cmmnd.val.2(In Spd.cntrl.cmmnd.)
P131	Spd.cmmnd.val.3(In Spd.cntrl.cmmnd.)
P132	Spd.cmmnd.val.4(In Spd.cntrl.cmmnd.)
P133	Spd.cmmnd.val.5(In Spd.cntrl.cmmnd.)
P134	Spd.cmmnd.val.6(In Spd.cntrl.cmmnd.)
P135	Spd.cmmnd.val.7(In Spd.cntrl.cmmnd.)
P136	Trq.cmmnd val.1(In Trq.cntrl.cmmnd.)
P137	Trq.comnd.val.2(In Trq.cntrl.cmmnd.)
P138	Trq.comnd.val.3(In Trq.cntrl.cmmnd.)
P139	Speed loop P gain division ratio
P140	Inertia
P141	Viscosity friction
P142	Speed loop FF2 compensation ratio
P143	Max. speed
P144	Notch filter center frequency
P145	Notch filter band width

[Tab. 3 - 1 (a)] Parameter list 1/3

No.	Name
P200	Position loop gain
P201	Servo lock gain
P202	Positioning complete range
P203	Positioning time over
P204	Backlash compensation value
P205	Feed forward ratio
P206	Feed forward shift ratio
P207	Over-flow detection pulse
P208	Deviation error detection pulse
P209	Motion selection at Deviation error
P210	S shape Accel./Decel. time
P211	Acceleration time 1
P212	Acceleration time 2
P213	Acceleration time 3
P214	Deceleration time 1
P215	Deceleration time 2
P216	Deceleration time 3
P300	Rotating direction selection
P301	Setting unit selection
P302	Command unit
P303	Electronic gear ratio numerator
P304	Electronic gear ratio denominator
P305	Index positioning range
P306	Forward software OT limit
P307	Reverse software OT limit
P308	Max. Forward positioning amount
P309	Max. Reverse positioning amount
P310	Machine travel amount
P400	Jog speed 1
P401	Jog speed 2
P402	Zero return method selection
P403	Zero point marker selection
P404	Zero return Speed
P405	Zero return creep speed
P406	Zero point constant
P407	Zero point set distance
P408	Position data reference point
P409	Auto.run permit condition selection
P410	Decel. time of Zero return from OT
P411	External trigger level selection

No.	Name
P500	Reserved
P501	Reserved
P502	LCD current posi. display selection
P503	MDI current posi. display selection
P504	Dedicated operation selection for MDI Index data edit
P510	Communication function selection
P512	Communication ID No.
P513	Data length select.(Ser.communi.)
P514	Parity select.(Serial communicate.)
P515	Baud rate select.(Ser.communi.)
P516	Extnl.inp.disable select.1 in Local
P517	Extnl.inp.enable select.1 in Remote
P518	Extnl.inp.disable select.2 in Local
P519	Extnl.inp.enable select.2 in Remote
P520	Reserved
P521	Communication group ID set 1
P522	Communicat.group response yes/no 1
P523	Communication group ID set 2
P524	Communicate.group response yes/no 2
P525	Communication group ID set 3
P526	Communicate.group response yes/no 3
P527	Communication group ID set 4
P528	Communicate.group response yes/no 4
P529	Communication group ID set 5
P530	Communicate.group response yes/no 5
P600	CIH signal spec. selection
P601	Pls.train cmmnd. sequence change
P602	Pulse train command multiplication ratio selection
P603	Pulse train command compensation numerator
P604	Pulse train command compensation denominator
P605	Pulse train feed forward ratio
P606	Pls.train feed forward shift ratio
P607	Pulse train feed forward filter time constant
P608	Pulse train communication Received / Transmitted data selection

[Tab. 3 - 1 (b)] Parameter list 2/3

No.	Name
P700	Monitor 1 selection
P701	Monitor 2 selection
P702	Speed zero range
P703	Rough matching range
P704	SON signal logic selection
P705	Hard.OT Enable/ Disable selection
P706	Delay time of Mode change confirm.
P707	Software limit switch position 1
P708	Software limit switch position 2
P709	Software limit switch position 3
P710	Stop method of Emergency stop
P711	Decel.time at Emergency stop
P712	Servo OFF delay time after Emergency stop
P713	Stop method at AC power cut
P714	Digital switch input spec.selection
P715	ALM/WNG signal logic selection
P716	RDY signal spec. selection
P717	Output signal function selection 1
P718	Output signal function selection 2
P719	PN signal spec. selection
P720	S Q B Write data 1
P721	S Q B Write data 2
P722	S Q B Write data 3
P723	S Q B Write data 4
P724	S Q B Read data 1
P725	S Q B Read data 2
P726	S Q B Read data 3
P727	S Q B Read data 4
P728	S Q B Read data 5
P729	S Q B Read data 6
P730	Reserved
P731	Reserved
P732	Reserved
P733	Reserved
P734	Brake output delay time
P736	Motor overheat error detection Enable/ Disable selection
P737	Extnl.inp.sig. input allocation
P738	Extnl.inp.sig. input allocation
P739	Extnl.inp.sig. input allocation
P740	Extnl.out.sig. output allocation
P741	Extnl.out.sig. output allocation
P742	Reset signal spec. selection

[Tab. 3 - 1 (c)] Parameter list 3/3

3 - 2 Parameter setting

[1] Parameter configuration

Group No.	Parameter	Group name
0	P 0 0 0 ~	Motor, Encoder parameter
1	P 1 0 0 ~	Driver adjustment parameter
2	P 2 0 0 ~	N C adjustment parameter
3	P 3 0 0 ~	Position adjustment parameter
4	P 4 0 0 ~	Run motion parameter
5	P 5 0 0 ~	Display,Edit,Communi .parameter
6	P 6 0 0 ~	Pulse train input parameter
7	P 7 0 0 ~	I/O signal parameter

[Tab. 3 - 2] Parameter configuration

[2] Display

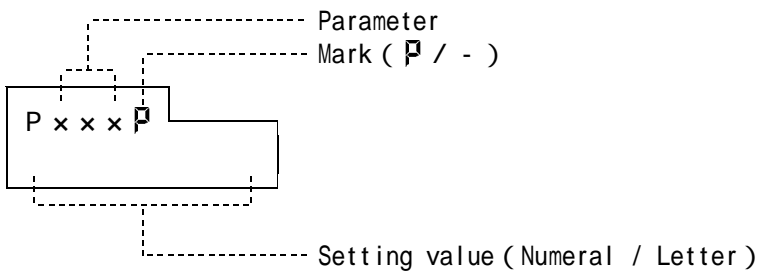

[3] Setting method

Parameter edition (Numeric input or menu selection) procedure is as follows.

ITEM No. set

I T E M P
 P P P P P 2 * 0 0

⚠ Set ITEM No. 「 2 * 0 0 」 .

* mark is a group No. . (Refer to Tab.3-2.)

⚠ After setting, when key is pushed, it moves to .

Parameter selection

P * 0 0 P
 P x x x x x x x x

⚠ Select a parameter to edit.

When key is pushed parameter No. increases.

When key is pushed parameter No. decreases.

⚠ At the time, current setting data are displayed.

Ⓐ 【In case of set by numeric input】

Data input 1

```

P 4 0 0 P
P P 0 0 1 0 . 0 0
    
```

Cursor

- ⚠ When \rightarrow key is pushed a cursor appears and input can be conducted.
- ⚠ When \leftarrow or \rightarrow key is pushed, numeric value or mark changes.
- ⚠ When \square key is pushed a cursor moves.
- ⚠ To cancel input data, push \leftarrow \rightarrow keys, together.

Data input 2

```

P 4 0 0 P
P P 0 1 2 3 . 4 5
    
```

Cursor

- ⚠ By the above operation, input setting data.

Data memory

```

P 4 0 0 P
P P 0 1 2 3 . 4 5
    
```

- ⚠ When \rightarrow key is pushed, a cursor disappears and set data are memorized.

Ⓑ 【In case of set by menu selection】

Data selection 1

```

P 3 0 0 P
P P FORWARD
    
```

Cursor

- ⚠ When \rightarrow key is pushed a cursor appears and selection can be conducted.
- ⚠ When \leftarrow or \rightarrow key is pushed, menu item is changed.
- ⚠ To cancel selected data, push \leftarrow \rightarrow keys, together.

Data selection 1

```

P 3 0 0 P
P P REVERSE
    
```

Cursor

- ⚠ By the above operation, select setting data.

Data memory

```

P 3 0 0 P
P P REVERSE
    
```

- ⚠ When \rightarrow key is pushed, a cursor disappears and set data are memorized.

3 - 3 Parameter specification

Param.	Parameter name	Timing	Run mode		Level	Setting unit	Setting range	Standard Ship.set (initial)								
			A	M		Function										
			Z	P												
《Group 0 》 [Motor, Encoder parameter]																
P000	Motor type	P	A	M	Z	P	S	None 000 ~ 999 000								
						Set an applied Servo motor type. Referring to 「Ap.-2 Applicable motor list」, please correctly set. To select dedicated motor, input 「999」 to this No.. Referring to 「Setting option spec.」, input dedicated motor parameter to P020 ~ P059. 【Caution】 If wrong value is set, runaway or fire could occur which is very dangerous.										
P001	Encoder type	P	A	M	Z	P	S	None Menu select. INC								
						Select an applied encoder type. <table border="1"> <tr> <td>Set</td> <td>Encoder type</td> </tr> <tr> <td>INC</td> <td>Incremental</td> </tr> <tr> <td>C-ABS</td> <td>Compact absolute</td> </tr> <tr> <td>ABS</td> <td>Absolute (Reserved)</td> </tr> </table>			Set	Encoder type	INC	Incremental	C-ABS	Compact absolute	ABS	Absolute (Reserved)
Set	Encoder type															
INC	Incremental															
C-ABS	Compact absolute															
ABS	Absolute (Reserved)															
P002	Encoder pulse selection	P	A	M	Z	P	S	PPR Menu select. 6000								
						1000 / 2000 / 2048 / 2500 / 4096 / 6000 Select number of pulses per encoder 1 turn. 【Caution】 If wrong value is set, runaway or fire could occur which is very dangerous.										
P004	Encoder pulse output division value	P	A	M	Z	P	F	None 01 ~ 32 01								
						Set numerator of encoder pulse output division ratio '(N of 1/N)'.										

item definition [Reflecting timing] I : Real time / R : Reset or power ON / P : Power ON / S : Motor stop
 item definition [Level] S : Setting is required / F : Run can be conducted by initial value / M : Reserved

Param.	Parameter name	Timing	Run mode		Level	Setting unit	Setting range	Standard Ship.set (initial)	
			A	M					
			O	P		Function			
《Group 0 》 [Motor, Encoder parameter]									
P005	ABS encoder resolution selection	P	A	M	Z	P	PPR	Menu select. 2048 / 4096	2048
							Select resolution of ABS encoder 1 turn.		
P006	ABS reference data	P	A	M	Z	P	Pulse	-16777216 ~ 16777215	00000000
							Set absolute data at machine reference position.		
P007	ABS reference machine position	P	A	M	Z	P	mm/°/in	-99999999 ~ 99999999	00000000
							Set machine position to machine refer. position. (A decimal point position depends on [P302])		
P008	Carrier frequency selection	P	A	M	Z	P	Hz	Menu select. 7.5K / 10K / 15K	10K
							Select carrier frequency of PWM.		

item definition [Reflecting timing] I : Real time / R : Reset or power ON / P : Power ON / S : Motor stop
item definition [Level] S : Setting is required / F : Run can be conducted by initial value / M : Reserved

Param.	Parameter name	Timing	Run mode		Level	Setting unit	Setting range	Standard Ship.set (initial)	
			A	M					O
			u	a	R	Function			
			o	u	s				
			A	M	Z				
			P						
《Group 0 》 [Motor, Encoder parameter]									
P020	Motor type · number of poles	P	A	M	Z	P	None	00000000 ~ 99999999	
							【Referring to Setting option spec., input 「999」 to Motor type parameter P000】		
P021	Rated torque current	P	A	M	Z	P	10mA	00001 ~ 65535	
							【Referring to Setting option spec., input 「999」 to Motor type parameter P000】		
P022	Rated speed (Field control base speed)	P	A	M	Z	P	rpm	00100 ~ 20000	
							【Referring to Setting option spec., input 「999」 to Motor type parameter P000】		
P023	Transit max. torque ratio	P	A	M	Z	P	%	100 ~ 300	
							【Referring to Setting option spec., input 「999」 to Motor type parameter P000】		
P024	Exciting current	P	A	M	Z	P	10mA	00000 ~ 65535	
							【Referring to Setting option spec., input 「999」 to Motor type parameter P000】 Effective only for NCS-FI type		
P026	Current loop coefficient	P	A	M	Z	P	None	00000 ~ 65535	
							【Referring to Setting option spec., input 「999」 to Motor type parameter P000】		
P028	R2 compensation change ratio	P	A	M	Z	P	0.01%	00000 ~ 65535	
							【Referring to Setting option spec., input 「999」 to Motor type parameter P000】 Effective only for NCS-FI type		
P030	Phase compensation angle	P	A	M	Z	P	deg	-100 ~ 100	
							【Referring to Setting option spec., input 「999」 to Motor type parameter P000】 Effective only for NCS-FS type		
P037	Torque command value change amount limiter value	P	A	M	Z	P	None	00000 ~ 65535	
							【Referring to Setting option spec., input 「999」 to Motor type parameter P000】		

item definition [Reflecting timing] I : Real time / R : Reset or power ON / P : Power ON / S : Motor stop

item definition [Level] S : Setting is required / F : Run can be conducted by initial value / M : Reserved

Param.	Parameter name	Timing	Run mode		Level	Setting unit	Setting range	Standard Ship.set (initial)
			A	M				
			O	P		Function		
《Group 0 》 [Motor, Encoder parameter]								
P040	Primary resistor	P	A	M	Z	P	S	μ 00000000 ~ 99999999
								【Referring to Setting option spec., input 「999」 to Motor type parameter P000】
P041	Secondary resistor	P	A	M	Z	P	S	μ 00000000 ~ 99999999
								【Referring to Setting option spec., input 「999」 to Motor type parameter P000】 Effective only for NCS-FI type
P042	Primary self inductance	P	A	M	Z	P	S	μ H 00000000 ~ 99999999
								【Referring to Setting option spec., input 「999」 to Motor type parameter P000】
P043	Secondary self inductance	P	A	M	Z	P	S	μ H 00000000 ~ 99999999
								【Referring to Setting option spec., input 「999」 to Motor type parameter P000】 Effective only for NCS-FI type
P044	Mutual inductance	P	A	M	Z	P	S	μ H 00000000 ~ 99999999
								【Referring to Setting option spec., input 「999」 to Motor type parameter P000】 Effective only for NCS-FI type
P045	Leakage coefficient	P	A	M	Z	P	S	10^{-6} 00000000 ~ 99999999
								【Referring to Setting option spec., input 「999」 to Motor type parameter P000】 Effective only for NCS-FI type
P046	Dead time compensation time	P	A	M	Z	P	S	10^{-7} sec 00000 ~ 65535
								【Referring to Setting option spec., input 「999」 to Motor type parameter P000】
P047	Current loop cut-off frequency	P	A	M	Z	P	S	rad/s 00000 ~ 65535
								【Referring to Setting option spec., input 「999」 to Motor type parameter P000】
P048	Current loop derivative time constant	P	A	M	Z	P	S	μ sec 00000 ~ 65535
								【Referring to Setting option spec., input 「999」 to Motor type parameter P000】

item definition [Reflecting timing] I : Real time / R : Reset or power ON / P : Power ON / S : Motor stop
item definition [Level] S : Setting is required / F : Run can be conducted by initial value / M : Reserved

Param.	Parameter name	Timing	Run mode		Level	Setting unit	Setting range	Standard Ship.set (initial)
			A	M O P				
			A	M Z P		Function		
《Group 0 》 [Motor, Encoder parameter]								
P049	Torque constant	P	A M Z P	S	10 ⁻⁶ Nm/A	00000000 ~ 99999999		
					【Referring to Setting option spec., input 「999」 to Motor type parameter P000】 Effective only for NCS-FS type			
P059	Special encoder pulse number	P	A M Z P	S	PPR	00000 ~ 30000		
					【Referring to Setting option spec., input 「999」 to Motor type parameter P000】 When 0 is set, setting value of P002「Encoder pulse selection」 is effective.			

item definition [Reflecting timing] I : Real time / R : Reset or power ON / P : Power ON / S : Motor stop
item definition [Level] S : Setting is required / F : Run can be conducted by initial value / M : Reserved

Param.	Parameter name	Timing	Run mode				Setting unit	Setting range	Standard Ship.set (initial)	
			A	M	O	P				
			Level	Function						
《Group 1 》 [Driver adjustment parameter]										
P100	Low speed gain range	I	A	M	Z	P	F	rpm	000 ~ 999	000
Set speed range of low speed gain when GSEL signal is OFF. When motor speed is less than this set, 「Speed loop gain」 「Speed loop integral time const.」 「Speed loop derivative time const.」 「Torque command filter frequency」 are changed to parameters in Low speed gain range ([P105], [P106], [P107], [P108]). But if set value is 「0」, they are not changed. And when motor speed is more than this set, control is conducted by parameters ([P101], [P102], [P102], [P104]).										
P101	Speed loop gain	I	A	M	Z	P	F	None	000 ~ 499	025
Set Speed loop gain. When it is set larger, though response becomes quicker, vibration may occur depending on machine system rigidly. If set is 「0」, a motor is in torque free.										
P102	Speed loop integral time constant	I	A	M	Z	P	F	m sec	000 ~ 999	020
Set time constant of Speed loop integral compensation. When it is set smaller, response becomes quicker. But if too small, vibration may easily occur. If set is 「0」 integral compensation is not conducted.										
P103	Speed loop derivative time constant	I	A	M	Z	P	F	μ sec	0000 ~ 9999	000
Set time constant of Speed loop derivative compensation. When it is set smaller, response becomes quicker. But if too small, vibration may easily occur. If set is 「0」 derivative compensation is not conducted.										
P104	Torque command filter frequency	I	A	M	Z	P	F	Hz	0000 ~ 1000 (1Hz : unit)	0500
Set Torque command filter (low pass) frequency. If resonance occurs in combination with a machine, fix it to insert a torque command filter. (anti-vibration) If set is 「0」 filter is invalid.										
P105	Speed loop gain / Low speed gain range	I	A	M	Z	P	F	None	000 ~ 499	025
Set Speed loop gain in Low speed gain range. (Description can be referred to [P101].)										
P106	Speed loop integral time constant / Low speed gain range	I	A	M	Z	P	F	m sec	000 ~ 999	020
Set time constant of Speed loop integral compensation in Low speed gain range. (Description can be referred to [P102].)										

item definition [Reflecting timing] I : Real time / R : Reset or power ON / P : Power ON / S : Motor stop
item definition [Level] S : Setting is required / F : Run can be conducted by initial value / M : Reserved

Param.	Parameter name	Timing	Run mode		Level	Setting unit	Setting range	Standard Ship.set (initial)
			A	M		Function		
			O	P				
《Group 1 》 [Driver adjustment parameter]								
P107	Speed loop derivative time constant / Low speed gain range	I	A	M	Z	P	F	μ sec 0000 ~ 9999 000 Set time constant of Speed loop derivative compensation in Low speed gain range. (Description can be referred to [P103].)
P108	Torque command filter frequency / Low speed gain range	I	A	M	Z	P	F	Hz 0000 ~ 1000 (1Hz : unit) 0500 Set Torque command filter (low pass) frequency in Low speed gain range.. (Description can be referred to [P104].)
P109	Torque limit value 1+	I	A	M	Z	P	F	% 000 ~ 300 (1% : unit) 300 Limit motor forward output torque limit value. If set is larger than peak torque, output torque is clamped at the peak torque. If set is 「0」, forward torque is not generated.
P110	Torque limit value 1-	I	A	M	Z	P	F	% 000 ~ 300 (1% : unit) 300 Limit motor forward output torque limit value. If set is larger than peak torque, output torque is clamped at the peak torque. If set is 「0」, reverse torque is not generated.
P111	Torque limit value 2+	I	A	M	Z	P	F	% -1 ~ 300 (1% : unit) -1 At TL signal ON or Alarm stop (but by parameter 「P115: Torque limit selection at Alarm stop」), set Forward torque limit value. -1 set : Limit by lower value of External torque limit + command and parameter [P109:Torque limit value 1+]. Other than -1 : Limit by lower value of this parameter and [P109:Torque limit value1]. And at the above status, If this parameter set is 「0」 forward torque is not generated.
P112	Torque limit value 2-	I	A	M	Z	P	F	% -1 ~ 300 (1% : unit) -1 At TL signal ON or Alarm stop (but by parameter 「P115: Torque limit selection at Alarm stop」), set Reverse torque limit value. -1 set : Limit by lower value of External torque limit - command and parameter [P110:Torque limit value 1+]. Other than -1 : Limit by lower value of this parameter and [P110:Torque limit value1]. And at the above status, If this parameter set is 「0」 reverse torque is not generated.

item definition [Reflecting timing] I : Real time / R : Reset or power ON / P : Power ON / S : Motor stop

item definition [Level] S:Setting is required / F : Run can be conducted by initial value / M : Reserved

Param.	Parameter name	Timing	Run mode		Level	Setting unit	Setting range	Standard Ship.set (initial)	
			A	M		Function			
			O	P					
			A	M	O	P			
			u	a	R	l			
			t	n	e	s.			
			o	u	t	t			
			A	M	Z	P			
《Group 1 》 [Driver adjustment parameter]									
P113	Auto.tuning trial run direction	R	·	·	·	F	None	Menu select.	BOTH
							BOTH / +ONLY / -ONLY		
						Select motor trial run direction in Auto.tuning.			
						Set	Contents		
						BOTH	Both		
						+ONLY	Forward		
						-ONLY	Reverse		
						Operation methods can be referred to the separate manual 『Volume: Basic function』.			
P114	Auto.tuning trial run speed ratio	R	·	·	·	F	None	0.00 ~ 1.00	0.30
							Set trial run speed in Auto.tuning by ratio to rated speed. When 「1.00」 is set a motor runs at rated speed. Operation methods can be referred to the separate manual 『Volume: Basic function』.		
P115	Torque limit selection at Alarm stop	I	A	M	Z	P	None	Menu select.	ALM.TL N
							ALM.TL N / ALM.TL Y		
						Select torque limit function for motor sudden stop at Alarm occurrence. ALM.TL N : Conducts torque limit in accordance with parameters [P109/ 110:Torque limit value 1 ±] ALM.TL Y : Conducts torque limit in accordance with parameters [P111/112:Torque limit value 2 ±]			
P116	Speed loop gain/ at GSEL signal ON	I	A	M	Z	P	None	000 ~ 499	025
							Sets gain at GSEL signal ON. (Description can be referred to [P101].)		
P117	Speed loop integral time constant / at GSEL signal ON	I	A	M	Z	P	m sec	000 ~ 999	020
							Set time constant of Speed loop integral compensation at GSEL signal ON. (Description can be referred to [P102].)		
P118	Speed loop derivative time constant / at GSEL signal ON	I	A	M	Z	P	μ sec	0000 ~ 9999	000
							Set time constant of Speed loop derivative compensation at GSEL signal ON. (Description can be referred to [P103].)		
P119	Torque command filter frequency / at GSEL signal ON	I	A	M	Z	P	Hz	0000 ~ 1000 (1Hz : unit)	0500
							Set Torque command filter (low pass) frequency at GSEL signal ON. (Description can be referred to [P104].)		

item definition [Reflecting timing] I : Real time / R : Reset or power ON / P : Power ON / S : Motor stop
item definition [Level] S : Setting is required / F : Run can be conducted by initial value / M : Reserved

Param.	Parameter name	Timing	Run mode			Level	Setting unit	Setting range	Standard Ship.set (initial)	
			A	M	O					P
			u	a	R	I				
			o	n	s.					
			A	M	Z	P				
Function										
《Group 1 》 [Driver adjustment parameter]										
P120	R2 compensation selection	I	A	M	Z	P	F	None	Menu select.	R2 OFF
								R2 OFF / R2 ID / R2 TH		
Select a method of R2 compensation(Output torque error compensation due to temperature drift) . R2 OFF : R2 compensation is not conducted. R2 ID : Identifies R2 from motor current and voltage and conducts compensation. R2 TH : Measures motor temperature and conducts compensation. But if a thermister (Temp. sensor) is not equipped with a motor, Alarm occurs. Effective only for NCS-FI type										
P121	Electric thermal detection selection	R	A	M	Z	P	F	None	Menu select.	STD
								STD / BIG		
Select detection method of Electric thermal. STD : Standard BIG : Big capacity 【Caution】 When BIG is used, install a thermister to a motor and select 「Enable」 of [P736: Motor over-heat error detection Enable/ Disable selection] or connect a thermostat or a thermal to protect the unit. Detection methods can be referred to the separate manual 『Volume: Basic function』 .										
P122	Non-coherence control Enable/ Disable selection	R	A	M	Z	P	F	None	Menu select.	DECUP ON
								DECUP OFF / DECUP ON		
Select Enable/ Disable of Non-coherence control . DECUP OFF : Disable DECUP ON : Enable										

item definition [Reflecting timing] I : Real time / R : Reset or power ON / P : Power ON / S : Motor stop

item definition [Level] S:Setting is required / F: Run can be conducted by initial value / M : Reserved

Param.	Parameter name	Timing	Run mode		Level	Setting unit	Setting range	Standard Ship.set (initial)
			A	M		Function		
			A	M <td></td> <td></td> <td></td> <td></td>				
			O	P <td></td> <td></td> <td></td> <td></td>				
			R	S <td></td> <td></td> <td></td> <td></td>				
			I	P <td></td> <td></td> <td></td> <td></td>				
			A	Z <td></td> <td></td> <td></td> <td></td>				
			P	<td></td> <td></td> <td></td> <td></td>				
《Group 1 》 [Driver adjustment parameter]								
P124	Speed command gain (voltage)	I	A . . .	F	V	06.00 ~ 10.00(10.01 ~ 100.00)	010.00	<p>Set full scale value (motor rated speed command) of External speed command voltage(DC voltage) . When set command voltage is inputted, motor runs at rated speed. Though value more than 10.0 can be inputted, max. input voltage is $\pm 10V$. Motor regenerative motion in the speed range than 10.0 can be conducted at motor max. speed or less, but drive could not be done.</p> <p>Sample) Set value is 100.00/2000rpm (Rate speed), and Speed command voltage input is 10V : Motor drive speed is $2000 * 10V / 100.00 = 200rpm$.</p> <p>Resolution of Speed command is max.at10V. When 6.00 is set the resolution is 6/10 of that of 10.00 set.</p>
P125	Speed command off-set	I	A . . .	F	mV	-999 ~ 999	000	Set off-set voltage of External speed command (DC voltage) . When External speed command voltage has off-set,by the off-set voltage, a motor slowly runs. Set this parameter to stop this motor motion caused by the off-set voltage.
P126	Torque command off-set	I	A . . .	F	mV	-999 ~ 999	000	Set off-set voltage of External torque command (DC voltage) .
P127	External Speed limit Enable/ Disable selection	R	A . . .	F	None	Menu select. SPD.LIM.N / SPD.LIM.Y	SPD.LIM.N	<p>Select whether motor speed shall be limited or not by External speed command (DC volt.) in Torque control command.</p> <p>SPD.LIM.N: No. Motor speed is limited by [P128 : Speed limit value] .</p> <p>SPD.LIM.Y: Yes. Motor speed is limited by lower value of [P128 : Speed limit value] and External speed command.</p>
P128	Speed limit value	I	A . . .	F	rpm	00000 ~ 99999	1000	Set motor speed limit value in Torque control command. When 120% or higher of rated speed is set, limit value becomes 120% of rated speed.

item definition [Reflecting timing] I : Real time / R : Reset or power ON / P : Power ON / S : Motor stop
item definition [Level] S:Setting is required / F: Run can be conducted by initial value / M : Reserved

Param.	Parameter name	Timing	Run mode		Level	Setting unit	Setting range	Standard Ship.set (initial)
			A	M		Function		
			O	P				
《Group 1 》 [Driver adjustment parameter]								
P136	Torque command value 1	I	A . . .	F	%	-300 ~ 300	030	Set command value and direction of internal Torque command 1 in Torque control command.
P137	Torque command value 2	I	A . . .	F	%	-300 ~ 300	050	Set command value and direction of internal Torque command 2 in Torque control command.
P138	Torque command value 3	I	A . . .	F	%	-300 ~ 300	080	Set command value and direction of internal Torque command 3 in Torque control command.
P139	Speed loop proportional gain division ratio	I	A M Z P	F	%	000 ~ 100	000	Set proportional gain division ratio of 2 free degree control in Speed loop. If large value is set, even if gain is set high, over-shoot can be depressed.
P140	Inertia	I	A M Z P	F	10 ⁻⁶ Kg·m ²	00000000 ~ 99999999	00000000	Set control system inertia. 【Caution】 If value is unknown, do not set it.
P141	Viscosity friction	I	A M Z P	F	10 ⁻⁶ N·m/rad/s	00000000 ~ 99999999	00000000	Set control system viscosity friction. 【Caution】 If value is unknown, do not set it.
P142	Speed loop FF2 compensation ratio	I	A M Z P	F	%	000 ~ 100	000	Set FF2 compensation ratio of Speed loop. 【Caution】 If proper values are not set to [P140:Inertia] and [P141:Viscosity friction], do not set this.

item definition [Reflecting timing] I : Real time / R : Reset or power ON / P : Power ON / S : Motor stop

item definition [Level] S : Setting is required / F : Run can be conducted by initial value / M : Reserved

Param.	Parameter name	Timing	Run mode		Level	Setting unit	Setting range	Standard Ship.set (initial)
			A	M				
			A	M		Z	P	Function
《Group 1 》 [Driver adjustment parameter]								
P143	Max. speed	P	A	M	Z	P	F	rpm
								00000 ~ 20000
Set motor max. speed. When 「0」 is set, motor rated speed becomes max. speed. In case of NCS-FI type When value other than 「0」 is set, Field control is conducted. In case of NCS-FS type Set 「0」 . 【Caution】 • At speed higher than motor rated speed, motor output torque feature and max. speed depends on individual type. • When value other than 「0」 is set to this set, reference (「Rated speed」 in this manual) of Analog monitor and Speed command becomes this set speed.								
P144	Notch filter center frequency	I	A	M	Z	P	F	Hz
								0000 ~ 4999
When resonance occurs in combination with a machine system, by setting the resonance frequency, avoid resonance. When 「0」 is set, Notch filter is invalid.								
P145	Notch filter band width	I	A	M	Z	P	F	Hz
								0000 ~ 4999
Set band width of P144 「Notch filter center frequency」								

item definition [Reflecting timing] I : Real time / R : Reset or power ON / P : Power ON / S : Motor stop
item definition [Level] S : Setting is required / F : Run can be conducted by initial value / M : Reserved

Param.	Parameter name	Timing	Run mode		Level	Setting unit	Setting range	Standard Ship.set (initial)
			A	M				
			A	M		Z	P	Function
《Group 2 》 [NC adjustment parameter]								
P200	Position loop gain	I	A	M	Z	P	F	S ⁻¹ 000 ~ 199 020
Set Position loop gain of motion in Auto./Manual/Zero return/Pulse train run mode. When this is set larger, though response becomes quicker, vibration may easily occur. If set is 「0」, since Position loop is open, Auto.run can not be conducted.								
P201	Servo lock gain	I	A	M	Z	P	F	S ⁻¹ 000 ~ 199 020
Set Position loop gain in Servo lock status, when Position deviation is within [P202:Positioning complete range]. When this is set larger, though response becomes quicker, vibration may easily occur. If set is 「0」, since Position loop is open, Servo lock can not be conducted.								
P202	Positioning complete range	R	A	.	Z	P	F	Pulse 000 ~ 999 010
Set output range of Positioning complete signal (PN). Setting unit is 4 times of applied encoder pulse number. 《Sample》 If Positioning complete range is determined ±10 pulse of the encoder, set value is 「040」.								
P203	Positioning time over	R	A	.	Z	.	F	sec 0.00 ~ 9.99 (10msec:unit) 0.00
Set acceptable time to actually reach in completion range after a command is completed in Positioning or Zero return.If Positioning is not completed within the time, Alarm signal (ALM) is outputted. But if set value is 「0.00」, Positioning time over detection is not conducted.								
P204	Backlash compensation value	R	A	M	Z	P	F	Pulse -999 ~ 999 000
Set backlash compensation amount in machine system. When travel direction reverses in Auto./Manual/Zero return/Pulse train run, Backlash compensation amount is added/ subtracted to motion. 「+」 mark is addition, and 「-」 mark is subtraction. Setting unit is 4 times of applied encoder pulse number. If set value is 「0」 Backlash compensation is not conducted.								

item definition [Reflecting timing] I : Real time / R : Reset or power ON / P : Power ON / S : Motor stop
item definition [Level] S:Setting is required / F : Run can be conducted by initial value / M : Reserved

Param.	Parameter name	Timing	Run mode		Level	Setting unit	Setting range	Standard Ship.set (initial)		
			A	M					O	P
			u	a		R	I	S	Function	
			A	M	Z	P				
			A	M	Z	P				
《Group 2 》 [NC adjustment parameter]										
P205	Feed forward ratio	R	A	M	Z	·	F	%	000 ~ 120	080
								Set Speed command feed forward ratio in Auto./ Manual / Zero return run mode. When this is set larger, though compliance becomes better in some case vibration may occur due to mis-matching with machine system. In the case, lower set a little and give some deviation to get stable motion. If set is 「0」 Feed forward control is not conducted.		
P206	Feed forward shift ratio	R	A	M	Z	·	F	%	000 ~ 100	001
								Set Speed command feed forward shift ratio in Auto./ Manual / Zero return run.		
P207	Over-flow detection pulse	R	A	M	Z	P	F	Pulse	01000 ~ 32767	24000
								Set Over-flow detection value of Position deviation. Setting unit is 4 times of applied encoder pulse number.		
P208	Deviation error detection pulse	R	A	M	Z	P	F	Pulse	00000 ~ 32767	00000
								Set acceptable range of Position deviation. Setting unit is 4 times of applied encoder pulse number. If set is 「0」, Deviation error detection is not detected.		
P209	Motion selection at deviation error	I	A	M	Z	P	F	None	Menu select.	CONTINUE
									STOP / CONTINUE	
Select motion when Position deviation exceeds [P208 : deviation error detection pulse] and Deviation error occurs. STOP(Alarm stop) Outputs Alarm signal(ALM) and a motor suddenly stops. CONTINUE(Motion continues.) Controls to lower deviation amount below deviation detection pulse when Deviation error is detected and continues motion. During deviation detection and completion in Auto./ Zero return and during the detection and motion stop in Manual / Pulse train, Warning signal (WNG) is outputted. When CONTINUE (Motion continues.) is selected, be careful to next points. Positioning time becomes long. Over-load error may easily occur. When excess deviation exists at Decel. , set 「000」 to Feed forward ratio of parameters [P205] and [P605].										

item definition [Reflecting timing] I : Real time / R : Reset or power ON / P : Power ON / S : Motor stop
item definition [Level] S : Setting is required / F : Run can be conducted by initial value / M : Reserved

Param.	Parameter name	Timing	Run mode		Level	Setting unit	Setting range	Standard Ship.set (initial)
			A	M				
			A	M		Z	P	Function
《Group 2 》 [NC adjustment parameter]								
P210	S shape Accel./ Decel addition time	R	A	M	Z	·	F	m sec 0000.0 ~ 1000.0 (0.1msec:unit) 0000.0
								Set addition time when 'S shape' is selected for motor Accel./ Decel. curve, S shape in Auto./ Manual/ Zero return run. When set value is 「0」, it is linear Accel./ Decel.. Accel. time becomes S shape addition time longer than set time of parameters [P211], [P212], and [P213]. Decel. time becomes S shape addition time longer than set time of [P214],[P215],and [P216]. Actual control time is set time × 1.5msec unit. For example when 2ms is set, time is 3ms (1.5×2).
P211	Accel. time 1	R	A	M	Z	·	F	sec 00.000 ~ 99.999 (1msec:unit) 00.500
								Set Accel. time from zero speed to rated speed. But a motor is accelerated by this parameter set plus set time (addition time) [P210]. It is effective in Auto./ Manual/ Zero return run.
P212	Accel. time 2	R	A	·	·	·	F	sec 00.000 ~ 99.999 (1msec:unit) 00.500
								Function is identical to [P211] but effective only in Auto. run.
P213	Accel. time 3	R	A	·	·	·	F	sec 00.000 ~ 99.999 (1msec:unit) 00.500
								Function is identical to [P211] but effective only in Auto. run.
P214	Decel. time 1	R	A	M	Z	·	F	sec 00.000 ~ 99.999 (1msec:Unit) 00.500
								Set Decel. time from rated speed to zero speed. But a motor is decelerated by this parameter set plus set time (addition time) [P210]. It is effective in Auto./ Manual/ Zero return run.
P215	Decel. time 2	R	A	·	·	·	F	sec 00.000 ~ 99.999 (1msec:unit) 00.500
								Function is identical to [P214] but effective only in Auto. run.
P216	Decel. time 3	R	A	·	·	·	F	sec 00.000 ~ 99.999 (1msec:unit) 00.500
								Function is identical to [P214] but effective only in Auto. run.

item definition [Reflecting timing] I : Real time / R : Reset or power ON / P : Power ON / S : Motor stop
item definition [Level] S:Setting is required / F: Run can be conducted by initial value / M : Reserved

Param.	Parameter name	Timing	Run mode		Level	Setting unit	Setting range	Standard Ship.set (initial)		
			A	M		O	P	Function		
《Group 3 》 [Position adjustment parameter]										
P300	Rotating direction selection	R	A	N	Z	P	F	None	Menu select.	FORWARD
								FORWARD / REVERSE		
			FORWARD	Forwa- rd	Motor forward rotation to Forward direction or positive data command.					
			REVERSE	Rever- se	Motor reverse rotation to Forward direction or positive data command					
P301	Setting unit selection	R	A	N	Z	P	F	None	Menu select.	[mm]
								[mm] / [°] / [in]		
P302	Command unit	R	A	N	Z	P	F	mm/ ° /in	Menu select.	0.01
								1 / 0.1 / 0.01 / 0.001		
P303	Electronic gear ratio numerator	R	A	N	Z	P	F	None	00001 ~ 65535	00001
								Set gear ratio between machine system drive shaft and motor shaft together with [P304 : Electro. gear ratio denominator] . If a load shaft of machine system rotates 'n' turns when a motor rotates 'm' turns, set 'n' to this parameter. Electronic gear setting sample and cautions can be referred to [P310 : Machine travel amount] .		
P304	Electronic gear ratio denominator	R	A	N	Z	P	F	None	00001 ~ 65535	00001
								Set gear ratio between machine system drive shaft and motor shaft together with [P303 : Electro. gear ratio numerator] . If a load shaft of machine system rotates 'n' turns when a motor rotates 'm' turns, set 'm' to this parameter. Electronic gear setting sample and cautions can be referred to [P310 : Machine travel amount] .		

item definition [Reflecting timing] I : Real time / R : Reset or power ON / P : Power ON / S : Motor stop

item definition [Level] S : Setting is required / F : Run can be conducted by initial value / M : Reserved

Param.	Parameter name	Timing	Run mode		Level	Setting unit	Setting range	Standard Ship.set (initial)	
			A	M		O	P	Function	
			u	t		n	s.		
《Group 3 》 [Position adjustment parameter]									
P305	Index data range	R	A	N	Z	P	F	mm/ ° /in 00000000 ~ 99999999 00000000	
								Set 1 turn data amount to a rotating machine. (A decimal point position depends on [P302].) By the set absolute position data range becomes 0~ ([This set] - 1). Except 「Index positioning」 or 「Spinner」 application, set 00000000. When 00000000 is set, Index positioning commands (INDX,SIND) and Spin commands (SPNS,SPNT,SPNP) can not be used.	
P306	Forward software OT limit	I	A	N	Z	P	F	mm/ ° /in -99999999 ~ 99999999 00000000	
								Set Forward travel limit point by distance from [P408: Position data reference point] . When power is ON and after Zero return complete, this is always effective. (A decimal point position depends on [P302].) But if set is 「0」, limit is not detected. 【Caution】 After power is turned ON, be sure to execute Zero return. Though [P408: Position data reference point] is reset when Zero return is completed, until the completion, Software OT limit is not detected. Since Software OT limit detects at command position, if delay deviation is large a motor may stop at front of Software OT limit position.	
P307	Reverse software OT limit	I	A	N	Z	P	F	mm/ ° /in -99999999 ~ 99999999 00000000	
								Set Reverse travel limit point by distance from [P408: Position data reference point] . When power is ON and after Zero return complete, this is always effective. (A decimal point position depends on [P302].) But if set is 「0」, limit is not detected. 【Caution】 After power is turned ON, be sure to execute Zero return. Though [P408: Position data reference point] is reset when Zero return is completed, until the completion, Software OT limit is not detected. Since Software OT limit detects at command position, if delay deviation is large a motor may stop at front of Software OT limit position.	

item definition [Reflecting timing] I : Real time / R : Reset or power ON / P : Power ON / S : Motor stop
item definition [Level] S : Setting is required / F : Run can be conducted by initial value / M : Reserved

Param.	Parameter name	Timing	Run mode		Setting unit	Setting range	Standard Ship.set (initial)
			A	M:O:P			
			u	a:R:I	Level		Function
			t	n			
			o	s.			
			u	t			
			A <td>M:Z:P</td> <td></td> <td></td> <td></td>	M:Z:P			
《Group 3 》 [Position adjustment parameter]							
P308	Max. Forward positioning amount	I	A . . .	F	mm/ ° /in	00000000 ~ 99999999	00000000
					Set max. Forward positioning amount to the below commands by incremental amount. (A decimal point position depends on [P302] .) If executed positioning amount of a command is larger than this set, the command is aborted by Alarm. But if set is 「0」, Forward positioning amount is not checked. Applicable commands : POS, INDX, SPOS, CONT, REPT SIND		
P309	Max. Reverse positioning amount	I	A . . .	F	mm/ ° /in	-99999999 ~ 00000000	00000000
					Set max. Reverse positioning amount to the below commands by incremental amount. (A decimal point position depends on [P302] .) If executed positioning amount of a command is larger than this set, the command is aborted by Alarm. But if set is 「0」, Reverse positioning amount is not checked. Applicable commands : POS, INDX, SPOS, CONT, REPT SIND		

item definition [Reflecting timing] I : Real time / R : Reset or power ON / P : Power ON / S : Motor stop
item definition [Level] S : Setting is required / F : Run can be conducted by initial value / M : Reserved

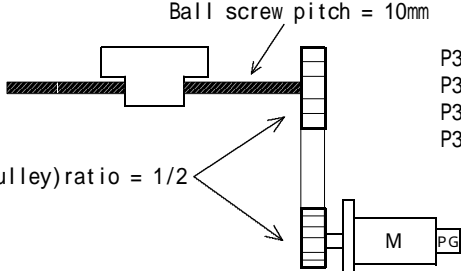
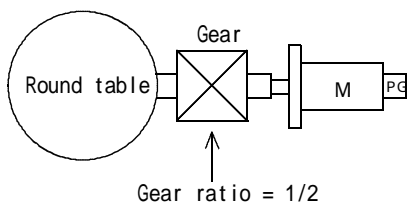
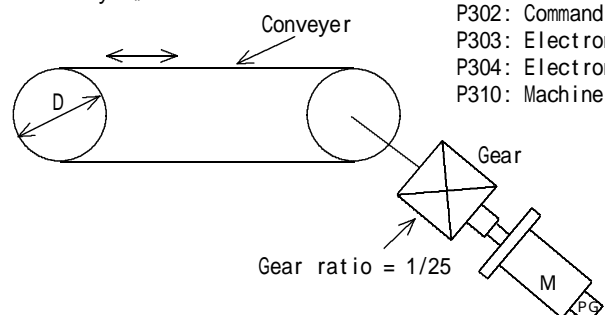
Param.	Parameter name	Timing	Run mode		Setting unit	Setting range	Standard Ship.set (initial)				
			A:M:O:P	A:R:L							
			u:a	t:i	o:s.	o:t	Level	Function			
			A:M	Z:P							
《Group 3 》 [Position adjustment parameter]											
P310	Machine travel amount	R	A	N	Z	P	F	mm/°/in	00000 ~ 65535	00000	Set load travel amount per 1 turn of machine system drive shaft (load shaft). (A decimal point position depends on [P302] .) But if set is 「0」 , 「Applied encoder pulse number ×4」 is used for this set in motion. 【Caution】 When motor rated speed set by Electronic gear ratio and Machine travel amount set is out of 100mm~2M (setting unit:sec) range, Alarm occurs and motion stops. (Setting unit depends on [P301] and [P302])
P303 P304 P310	《Electronic gear ratio · machine travel amount parameter setting sample》										
《In case of ball screw》											
Ball screw pitch = 10mm											
											
Gear(pulley)ratio = 1/2											
P302: Command unit = 0.01mm P303: Electronic gear ratio numerator = 1 P304: Electronic gear ratio denominator = 2 P310: Machine travel amount = 10.00mm											
《In case of round table》											
											
Gear ratio = 1/2											
P302: Command unit = 0.1° P303: Electronic gear ratio numerator = 1 P304: Electronic gear ratio denominator = 2 P310: Machine travel amount = 360.0°											
《In case of conveyer》											
											
Gear ratio = 1/25											
P302: Command unit = 0.001mm P303: Electronic gear ratio numerator = 1 P304: Electronic gear ratio denominator = 25 P310: Machine travel amount = Dmm											

item definition [Reflecting timing] I : Real time / R : Reset or power ON / P : Power ON / S : Motor stop
item definition [Level] S:Setting is required / F : Run can be conducted by initial value / M : Reserved

Param.	Parameter name	Timing	Run mode		Level	Setting unit	Setting range	Standard Ship.set (initial)		
			A	M					O	P
			A	M	O	P	Function			
			A	M	Z	P				
《Group 4 》 [Run motion parameter]										
P400	Jog speed 1	S	·	M	·	·	F	mm/sec /sec in/sec	0000001 ~ 9999999	0001000
Set Jog speed when Jog speed selection signal (JOSP signal) is OFF. (A decimal point position depends on [P302])										
P401	Jog speed 2	S	·	M	·	·	F	mm/sec /sec in/sec	0000001 ~ 9999999	0002000
Set Jog speed when Jog speed selection signal (JOSP signal) is ON. (A decimal point position depends on [P302])										
P402	Zero return method selection	S	A	·	Z	·	F	None Menu select. STD.HOME / LS LESS / STOP HOME / OT HOME	STD.HOME	
Select Zero return method. STD.HOME (Standard Zero return) After Zero point decel. LS is detected, detected position by Marker becomes new Zero point. LS LESS (No LS Zero return) Decel. control by Zero point decel.LS is not made and positioned data by Marker detection becomes new Zero point. STOP HOME(On the spot Zero return) Current place becomes new Zero point without any motion. OT HOME(OT back Zero return) After Zero point decel.LS is detected, detected position by Marker becomes new Zero point. If OT for motion direction is detected before Zero point decel. LS is detected, motion changes to opposite direction. And when 「NON.MARK」 is set to P403, motion is conducted based on Zero point decel. LS without Marker signal. Description can be referred to 「5-5-2 Zero return mode」 of the manual Volume: Basic function.										
P403	Zero point marker selection	R	A	·	Z	·	F	None Menu select. ENC.MARK / NON.MARK	ENC.MARK	
Select if Encoder marker is used for Zero point marker. ENC.MARK : Encoder marker NON.MARK : Not marker										

item definition [Reflecting timing] I : Real time / R : Reset or power ON / P : Power ON / S : Motor stop

item definition [Level] S:Setting is required / F: Run can be conducted by initial value / M:Reserved

Param.	Parameter name	Timing	Run mode		Setting unit	Setting range	Standard Ship.set (initial)				
			A	M				O	P		
			u	a	R	l	Level	Function			
			t	n	e	s.					
			o	u	t						
			A	M	Z	P					
《Group 4 》 [Run motion parameter]											
P404	Zero return speed	S	A	·	Z	·	F	mm/sec °/sec in/sec	0000001 ~ 9999999	0001000	Set initial speed in Zero return. (A decimal point position depends on [P302]) Both of FJ and RJ signals are effective in Zero return start. HOME command speed is this set value. Upper limit of motion speed is applied motor rated speed.
P405	Zero return creep speed	R	A	·	Z	·	F	mm/sec °/sec in/sec	0000001 ~ 9999999	0000100	Set Creep speed in Zero return after Zero point decel.LS is detected. (A decimal point position depends on [P302]) Normally, set it 1/100 or less of motor rated speed. In case of no LS Zero return,from the first, this set value is applied or motion speed.
P406	Zero point position constant	R	A	·	Z	·	F	mm/ ° /in	00000000 ~ 99999999	00010000	Set distance from Zero point decel.LS detection to start Marker signal detection in Zero return. (A decimal point position depends on [P302]) Set longer value than the distance to enable deceleration from Zero return speed to Zero return creep speed. And when 「NON.MARK」 is set to P403,motion is conducted based on Zero point decel. LS without Marker signal. Description can be referred to 「5-5-2 Zero return mode」 of the manual Volume: Basic function. 【Caution】 If this set value is small when Zero return speed is high, a motor suddenly decelerates or stops. Therefore, set sufficient value to decelerate to Creep speed.

item definition [Reflecting timing] I : Real time / R : Reset or power ON / P : Power ON / S : Motor stop
item definition [Level] S:Setting is required / F : Run can be conducted by initial value / M : Reserved

Param.	Parameter name	Timing	Run mode		Setting unit	Setting range	Standard Ship.set (initial)	
			A	M				
			O	P	Level			
			A	M				
			Z	P				
Function								
《Group 4 》 [Run motion parameter]								
P407	Zero point set distance	R	A	Z	F	mm/ ° /in	-99999999 ~ 99999999	00000000
<p>Set+ travel distance from Marker signal detection point in Zero return. This is used for fine adjustment of Marker signal position and Machine reference point position. (A decimal point position depends on [P302]) In case of standard and OT back Zero return Positioning is executed for same direction of Zero return when a mark is 「+」 and opposite direction when the mark is 「-」. In case of no LS Zero return Positioning is executed for same direction of Zeroreturn. When set is 「0」,Zero return is completed when Marker signal is detected. When set value is smaller than distance from Zero return creep speed to stop, over-shoot will occur when Zero return is completed. And when 「NON.MARK」is set to P403, motion is conducted based on Zero point decel.LS without Marker signal. Description can be referred to 「5-5-2 Zero return mode」 of the manual Volume: Basic function.</p>								
P408	Position data reference	R	A	Z	F	mm/ ° /in	-99999999 ~ 99999999	00000000
<p>Set Absolute position data reference position by distance from Machine reference point. (A decimal point position depends on [P302]) Set value is entered when Zero return is completed. If Positioning is conducted after power is turned ON without executing Zero return, the power ON position becomes Absolute position data reference position . Software OT limit value of parameters [P306] and [P307] refers to this Position data re-ference point.</p>								
P409	Auto. run permit condition selection	S	A	.	.	F	None	AUTO.N
<p>Menu select. AUTO.N / AUTO.Y</p> <p>Select Auto. run start permit condition. AUTO.N (after Zero return completion) Auto. run start can be conducted after Zero returns completed. But if an external not-permit factor exists, this is not permitted. AUTO.Y (No condition) At any time Auto.run can be started. But if an external not-permit factor exists, this is not permitted.</p>								

item definition [Reflecting timing] I : Real time / R : Reset or power ON / P : Power ON / S : Motor stop
item definition [Level] S : Setting is required / F : Run can be conducted by initial value / M : Reserved

Param.	Parameter name	Timing	Run mode		Level	Setting unit	Setting range	Standard Ship.set (initial)
			A	M				
			u	a		R	l	
			t	n	e	s.		
			o	u	t			
			A	M	Z	P		
Function								
《Group 4 》 [Run motion parameter]								
P410	Decel. time of OT back Zero return at OT	R	A	·	Z	·	F	
						sec	00.00 ~ 99.99 (10msec:unit)	00.50
						Set Decel.time from motor rated speed to stop. When S shape decel. Curve is selected by [P210],this set value is added to motor Decel. time. This set is effective only for reverse motion at OT in OT back Zero return.		
P411	External trigger level selection	R	A	·	·	·	F	
						None	Menu select.	TRG.EDGE
						TRG.EDGE / TRG.LEVEL		
						Select 「ON edge」 or 「ON level」 receipt for External trigger signal. TRG.EDGE : ON edge receipt for External trigger signal TRG.LEVEL : ON level receipt for External trigger signal (When this signal is ON, in Auto. start or restart from Hold / Block stop, External trigger signal is received.)		

item definition [Reflecting timing] I : Real time / R : Reset or power ON / P : Power ON / S : Motor stop
item definition [Level] S : Setting is required / F : Run can be conducted by initial value / M : Reserved

Chapter 4 Index data

4 - 1 Index data list

Index data	Index data name	Type	Function
IX00 ⋮ IX49	Index data 0 0 ⋮ Index data 4 9	Hold	Index data which retains data against Power OFF. But re-writing is max. 10000 times.
IX50 ⋮ IX53	Index data 5 0 ⋮ Index data 5 3	OClear	Voluntary Index data which do not retain data against Power OFF. It is 「0」 at Power ON.
IX54	Index data 5 4	OClear	Index data for BCD 8 digits + mark and only for NCS-FI/FS12 type. For other types, it is voluntary Index data.
IX55 IX57	Index data 5 5 Index data 5 7		Index data for Digital switch unit (SWU-500 series) numeric number and only for NCS-FI/FS12 type. For other types, it is voluntary Index data.
IX58 ⋮ IX60	Index data 5 8 ⋮ Index data 6 0	OClear	Voluntary Index data which do not retain data against Power OFF. It is 「0」 at Power ON.
IX61	Index data 6 1	OClear	Index data to be off-set No. of Index data No. when Index data 1000 ~ 1999 is specified by Command item data.
IX62	Index data 6 2	OClear	Index data for data of output voltage to Analog monitor. Data value : Output voltage relation -499:-10V, 0:0V, 499:+10V
IX63	Index data 6 3	OClear	Index data for data of output voltage to Analog monitor . Data value : Output voltage relation -499:-10V, 0:0V, 499:+10V
IX64	Index data 6 4		Index data for Speed command analog input value. -1707:-10V, 1707:10V
IX65	Index data 6 5		Index data for Torque command analog input value. -2047:-10V、2047:10V

[Tab. 4 - 1 (a)] Index data list 1/2

Index data	Index data name	Type	Function
IX66	Index data 6 6		Index data for current position
IX67	Index data 6 7	0Clear	Index data which counts number down every 10msec when inputted numeric value is other than 0.
IX68	Index data 6 8	0Clear	Voluntary Index data which do not retain data against Power OFF. It is 「0」 at Power ON.
IX69	Index data 6 9	0Clear	Index data for output data for General output signal.
IX70 ⋮ IX99	Index data 7 0 ⋮ Index data 9 9	0Clear	Voluntary Index data which do not retain data against Power OFF. It is 「0」 at Power ON.
IX100 ⋮ IX999	Index data 1 0 0 ⋮ Index data 9 9 9	0Clear / Hold	Voluntary Index data which do not retain data against Power OFF. It is 「0」 at Power ON. But if an extended memory (option) is equipped, data contents are retained against Power OFF. And at the time Re-write times are not limited.

[Tab. 4 - 1 (b)] Index data list 2/2

[Tab. 4 - 1] Supplement of Index data list description

Index data 6 1 (IX61)

Index data 61 is effective when 1000 ~ 1999 is set at Index data setting of each command. In the case, 「Index data 61 contents + (Set Index data No. - 1000)」 is actually referred Index data No.

Sample) When Index data 61 contents are 「200」 and Index data set is 「IX1030」, actually referred Index data are as follows.

Actually referred Index data

= Index data [Index data 61 contents + (Set Index data No. - 1000)]
= Index data [200 + (1030 - 1000)]
= Index data 230 (IX230)

If different motion of Positioning data, Speed, etc. is planned in the same sequence motion by this Index data, Index data No. change in a command is not required and only by Index data 61 contents change, it can be executed, which can simplify program steps.

「0 Clear」 in Type column

「0 Clear」 data in Type column do not retain Index data contents and conduct 0 Clear when power is OFF.

It is suitable for data which can be cleared when power is OFF or varying data as current position, etc. .

4 - 2 Index data setting

[1] Function

Index data are used on a command as Position/ Speed/ Time/ Output/ Address/ Looping time/ / Processing data and can be specified instead of numeric data.

When Index data are specified on a command, the unit executes the commandcontrols in accordance with numeric contents of the specified Index data.

Index data setting method can be referred to the individual command description.

[2] Unit , Setting range

Unit : Depends on each command setting unit.

Setting range : -99999999 ~ 99999999

(A decimal point position depends on [P302 : Command unit] .)

Initial value : 00000000

[3] Display

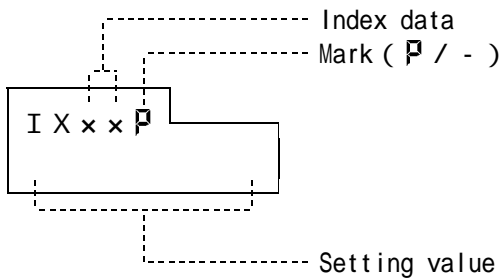

[4] Setting method

1) Index data edit (IX00 ~ IX99) procedure is as follows.

ITEM No. setting

```

ITEM No. setting
ITEM P
PPPPP 1 0 0 1
    
```

- △ Sets ITEM No. 「 1 0 0 1 」 .
- △ After setting, when \square key is pushed, it moves to .

Index data selection

```

Index data selection
IX 0 0 P
0 0 0 0 0 0 . 0 0
    
```

- △ Select Index data to edit.
- △ When \downarrow key is pushed, Index data No. increases..
- △ When \uparrow key is pushed, Index data No. decreases.
- △ At the time, currently set data are displayed.

Data input 1

```

Data input 1
IX 0 0 P
0 0 0 0 0 0 . 0 0
    
```

Cursor

- △ When \square key is pushed, a cursor appears and data can be inputted.
- △ When \downarrow or \uparrow key is pushed, numeric value or a mark in the cursor column changes.
- △ When \square key is pushed, the cursor moves.
- △ To cancel input data, push $\downarrow \uparrow$ keys at once.

Data input 2

```

Data input 2
IX 0 0 P
0 0 0 1 2 3 . 4 5
    
```

Cursor

- △ By the above operation, input setting data.

Data memory

```

Data memory
IX 0 0 P
0 0 0 1 2 3 . 4 5
    
```

- △ When \square key is pushed, a cursor disappears and setting data is memorized.

2) Index data edit (IX100 ~ IX999) procedure is as follows.

ITEM No. setting

```

ITEM No. setting
ITEM P
PPPPP 5 5 0 0
    
```

- △ Set ITEM No. 「 5 5 0 0 」 (IX500 ~ IX599 edit).
- △ After setting, when \square key is pushed, it moves to .

Index data selection

```

Index data selection
E 5 0 0 P
0 0 0 0 0 0 . 0 0
    
```

- △ Select Index data to edit.(E500 is IX500.)
- △ When \downarrow key is pushed, Index data No. increases.
- △ When \uparrow key is pushed, Index data No. decreases.
- △ At the time, currently set data are displayed.

and below No. can be referred to Index data edit (IX00 ~ IX99) procedure and identical No. .

Chapter 5 Command

5 - 1 Command list

Gro-up	Title	Command name	Function
0 MOTION COMMAND	N O P	No function [No OPeration]	No motion
	P O S	Positioning [POSiTioning]	Executes Positioning.
	H O M E	Zero return [HOMe positioning]	Executes Zero return.
	I N D X	Index Positioning [INDeX positioning]	Executes Positioning rotating work to shorter rotating direction.
1 NO OPTION COMMAND	M	M output [M out]	Waits for M complete after sending M output and M strobe signals.
	T I M E	Timer [TIMER]	Waits for specified time.
	P E N D	Program end [Program END]	Finishes executing Program.
	C A L L	Subroutine call [sub-routine CALL]	Repeats Subroutine specified times.
	R E T	Subroutine return [sub-routine RETurn]	Indicates completion of specified Subroutine and returns to caller address.
2 PROCESSOR COMMAND	I M O V	Transfer [Indirect MOVe]	Transfers specified data to Index data.
	A D D	Addition [ADDition]	Executes Addition and transfers the results to Index data.
	S U B	Subtraction [SUBtraction]	Executes Subtraction and transfers the results to Index data.
	M U L	Multiplication [MULtiplcation]	Executes Multiplication and transfers the results to Index data.
	D I V	Division [DIVision]	Executes Division and transfers the results to Index data.
	A N D	Logical AND [AND]	Executes Logical AND and transfers the results to Index data.
	O R	Logical OR [OR]	Executes Logical OR and transfers the results to Index data.
	X O R	Exclusive logical OR [eXclusive OR]	Executes Exclusive logical OR and transfers the results to Index data.
3 JUMP COMMAND	J M P	Un-conditional jump [JuMP]	Jumps to specified address without any condition.
	J Z	0 jump [Jump if Zero]	Jumps to specified address if branch decision (Index data) is 0.
	J N Z	Not 0 jump [Jump if Not Zero]	Jumps to specified address if branch decision (Index data) is not 0.
	J G	Greater than 1 jump [Jump if Greater than zero]	Jumps to specified address if branch decision (Index data) is 1 or greater.
	J L	Less than - 1 jump [Jump if Less than zero]	Jumps to specified address if branch decision (Index data) is -1 or less.

[Tab. 5 - 1 (a)] Command list 1/3

Group	Title	Command name	Function
5 C o n t i n u o u s m o t i o n c o m m a n d	S P N S	Spin speed [SPiN Speed]	Achieves specified speed (rpm) for set Accel./ Decel. time.
	S P N T	Spin timer [SPiN Timer]	Retains rotating status reached by Spin speed command for specified time.
	S P N P	Spin positioning [SPiN POSitioning]	Executes Positioning from rotating status at Spin speed to specified position for set time.
	S P O S	Positioning [Sequential POSitioning]	Function is same as [POS] command and Program is continued even after the motion is completed.
	C O N T	Simple continuous positioning [CONTinue POSitioning]	During this command continues, continues motion without stop. And if this is last or single command, function is same as SPOS.
	R E P T	Repeat positioning [REPeaT POSitioning]	Repeats specified Positioning set times.
	S H O M	Zero return [Sequential HOME positioning]	Function is same as [HOME] command and Program is continued even after the motion is completed.
	S I N D	Index Positioning [Sequential INDeX positioning]	Function is same as [INDX] command and Program is continued even after the motion is completed.

[Tab. 5 - 1 (b)] Command list 2/3

Group	Title	Command name	Function
4 D r i v e r c o m m a n d	T R Q	Torque control [ToRQue]	Executes Torque control by External torque command (Analog input command) or Internal torque command.
	S P D	Speed control [SPeeD]	Executes Speed control by External speed command (Analog input command) or Internal speed command.

[Tab. 5 - 1 (c)] Command list 3/3

5 - 2 Command setting

[1] Common setting items

Accel./Decel. time selection

Conduct setting of Acceleration and Deceleration time by parameters and select a combination from the below tabulation.

Accel./ Decel. time selection	Accel./ Decel time setting (parameter)
S E L . 1	Accel.time is set [P211 : Accel.time 1] . Decel.time is set [P214 : Decel.time 1] .
S E L . 2	Accel.time is set [P212 : Accel.time 2] . Decel.time is set [P215 : Decel.time 2] .
S E L . 3	Accel.time is set [P213 : Accel.time 3] . Decel.time is set [P216 : Decel.time 3] .

[Tab. 5 - 2] Combination of Accel./ Decel. time

General output

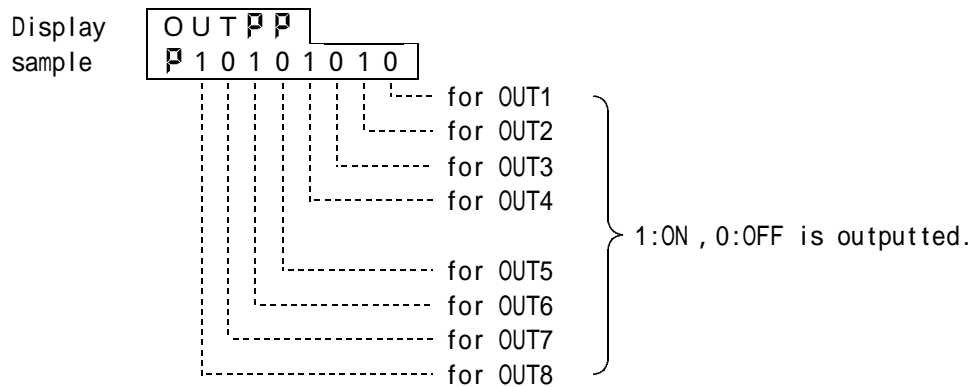

M output

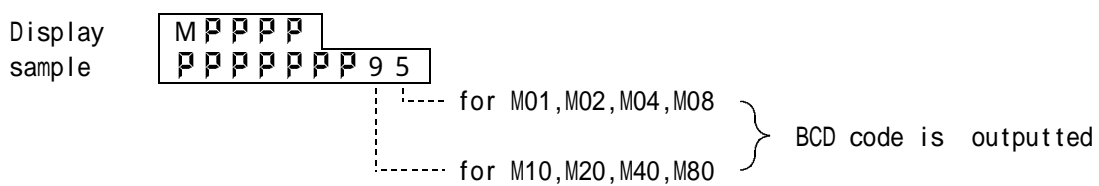

[2] Setting method

Command Edit procedure is as follows.

ITEM No. setting

```

ITEM P
PPPPP 1002
    
```

- △ Set ITEM No. 「1002」.
- △ After setting, when \square key pushed, it moves to .

Edit address input 1

```

ADDR P
PPPPPP 000
    
```

Cursor

- △ When \square key is pushed, a cursor appears and data can be inputted.
- △ When \downarrow or \leftarrow key is pushed, numeric value in the cursor column changes.
- △ When \square key is pushed the cursor moves.
- △ To cancel input data, push $\downarrow \leftarrow$ keys at once.

Edit address input 2

```

ADDR P
PPPPPP 125
    
```

Cursor

- △ By the above operation, input Edit address.

Edit address decision

```

ADDR P
PPPPPP 125
    
```

- △ When \square key is pushed, a cursor disappears and Edit address is decided.
- △ After decision, when \downarrow key is pushed, it moves to .

Edit command selection

```

CMD 0 P
PPPPPP NOP
    
```

Cursor

- △ When \square key is pushed, a cursor appears and data can be inputted.
- △ Push \square key to select command group.
- △ Push \downarrow or \leftarrow key to select Edit command.

Edit command decision

```

CMD 5 P
PPPPPP SPOS
    
```

- △ When \square key is pushed, a cursor disappears and Edit command is decided.
- △ After decision, when \downarrow key is pushed, it moves to .

Edit of each setting item of selected command

Refer to the command specification described from next page.

Edit (Numeric value input or menu selection) procedure of each setting item is identical to Parameter edit.

5 - 3 Command specification

Title	Command name	B S	Setting data		
			Data	Setting unit	Setting range (Direct data) (Index data)
Function					
《Group 0 》 [Motion command]					
N O P	No function [No OPeration]	No	None	None	None
			• No motion		
P O S	Positioning [POSitioning]	No	POS [Positioning position · direction]	mm/ ° /in	-99999999 ~ 99999999 IX0000 ~ IX1999
			A/I [Absolute position /Relative position]	None	ABSOLUTE / INCREMENT
			F [Positioning speed]	mm, ° ,in /sec	0000000 ~ 9999999 IX0000 ~ IX1999
			UPDN [Accel./Decel.time]	None	SEL.1 / SEL.2 / SEL.3
			TRG [External trigger position]	mm/ ° /in	00000000 ~ 99999999 IX0000 ~ IX1999
			OUT [General output]	Binary number	00000000 ~ 11111111 IX0000 ~ IX1999
H O M E	Zero return [HOME positioning]	No	TYPE [Zero return method]	None	STD.HOME / LS LESS / STOP HOME / OT HOME
			DIR [Motion direction]	None	FORWARD / REVERSE
			OUT [General output]	Binary number	00000000 ~ 11111111 IX0000 ~ IX1999

Title	Command name	B S	Setting data		
			Data	Setting unit	Setting range (Direct data) (Index data)
			Function		
《Group 0 》 [Motion command]					
I N D X	Index Positioning [INDeX positioning]	No	POS [Positioning position · direction]	mm/ ° /in	00000000 ~ 99999999 IX0000 ~ IX1999
			F [Positioning speed]	mm, ° ,in /sec	00000000 ~ 99999999 IX0000 ~ IX1999
			UPDN [Accel./ Decel.time]	None	SEL.1 / SEL.2 / SEL.3
			OUT [General output]	Binary number	00000000 ~ 11111111 IX0000 ~ IX1999
			<ul style="list-style-type: none"> • Executes Positioning rotating work to shorter rotating direction. • General output can be sent when motion starts. • Finishes Program after motion is completed. 		

Title	Command name	B	Setting data		
			Data	Setting unit	Setting range (Direct data) (Index data)
		S	Function		
《Group 1 》 [No motion command]					
M	M output [M out]	Ys	M [M output]	None	00 ~ 99 IX0000 ~ IX1999
			<ul style="list-style-type: none"> • Waits for M complete signal after sending M output and M strobe signal. • Outputted M output retains data until a command in effective setting status for next M output is executed. • If this command is executed with M complete input, M strobe is not outputted until the input signal is OFF. 		
T I M E	Timer [TIMER]	Ys	Time [Timer time]	0.01sec	000000.00 ~ 999999.99 IX0000 ~ IX1999
			Out [General output]	Binary number	00000000 ~ 11111111 IX0000 ~ IX1999
			<ul style="list-style-type: none"> • Waits for specified time. • General output can be sent when motion starts. 		
P E N D	Program end [Program END]	No	None	None	None
			<ul style="list-style-type: none"> • Finishes executing Program. • When this command is completed, Program end signal (PEND) and Auto. run ready signal (PRDY) is outputted. • General output and M output are retained. 		
C A L L	Subroutine call [sub-routine CALL]	Ys	CADR [Called address]	None	000 ~ 279 IX0000 ~ IX1999
			REPT [Looping time]	None	00000 ~ 65535 IX0000 ~ IX1999
			<ul style="list-style-type: none"> • Repeats Subroutine specified by CADR (REPT times). • Nesting (Looping time of executing this command without conducting return) can be conducted max. 8 times. • When Looping time is 「0」, this command is neglected and next command is executed. 		
R E T	Subroutine return [sub-routine RETURN]	Ys	None	None	None
			<ul style="list-style-type: none"> • Finishes called Subroutine and returns to caller address. • When Subroutine is executed specified time, executing address is changed to next address of the caller. 		

Title	Command name	B	Setting data		
			Data	Setting unit	Setting range (Direct data) (Index data)
		S	Function		
《Group 2 》 [Processing command]					
I M O V	Transfer [Indirect MOVE]	No	DST [Transfer destination]	None	IX0000 ~ IX1999
			SOC [Transfer origin data]	None	-99999999 ~ 99999999 IX0000 ~ IX1999
			<ul style="list-style-type: none"> Transfers specified data to Index data. <p>Expression : D S T (Index) S O C</p>		
A D D	Addition [ADDition]	No	DST [Addition results transfer destination]	None	IX0000 ~ IX1999
			SOC1 [Addition factor 1]	None	-99999999 ~ 99999999 IX0000 ~ IX1999
			SOC2 [Addition factor 2]	None	-99999999 ~ 99999999 IX0000 ~ IX1999
			<ul style="list-style-type: none"> Executes Addition and transfers the results to Index data. In case of Index data, a decimal point is neglected and numeric value is handled as integer for processing. (Sample: 1.25 is handled as 125 for processing.) Processing results are clumped at ± 99999999. <p>Expression : D S T (Index) S O C 1 + S O C 2</p>		
S U B	Subtraction [SUBtraction]	No	DST [Process. results transfer destination]	None	IX0000 ~ IX1999
			SOC 1 [Subtraction factor1]	None	-99999999 ~ 99999999 IX0000 ~ IX1999
			SOC 2 [Subtraction factor2]	None	-99999999 ~ 99999999 IX0000 ~ IX1999
			<ul style="list-style-type: none"> Executes Subtraction and transfers the results to Index data. In case of Index data, a decimal point is neglected and numeric value is handled as integer for processing. (Sample: 1.25 is handled as 125 for processing.) Processing results are clumped at ± 99999999. <p>Expression : D S T (Index) S O C 1 - S O C 2</p>		

Title	Command name	B	Setting data		
			Data	Setting unit	Setting range (Direct data) (Index data)
		S	Function		
《Group 2 》 [Processing command]					
M U L	Multiplication [MULTiplication]	No	DST [Process. results transfer destination]	None	IX0000 ~ IX1999
			SOC 1 [Multiplication factor1]	None	-99999999 ~ 99999999 IX0000 ~ IX1999
			SOC 2 [Multiplication factor2]	None	-99999999 ~ 99999999 IX0000 ~ IX1999
			<ul style="list-style-type: none"> Executes Multiplication and transfers the results to Index data. In case of Index data, a decimal point is neglected and numeric value is handled as integer for processing. (Sample: 1.25 is handled as 125 for processing.) Processing results are clumped at ± 99999999. Expression : D S T (Index) S O C 1 × S O C 2		
D I V	Division [DIVision]	No	DST 1 [Division remainder transfer destination]	None	IX0000 ~ IX1999
			DST2 [Division quotient transfer destination]	None	IX0000 ~ IX1999
			SOC 1 [Dividend]	None	-99999999 ~ 99999999 IX0000 ~ IX1999
			SOC 2 [Divisor]	None	-99999999 ~ 99999999 IX0000 ~ IX1999
<ul style="list-style-type: none"> Executes Division and transfers the results to Index data. In case of Index data, a decimal point is neglected and numeric value is handled as integer for processing. (Sample: 1.25 is handled as 125 for processing.) Expression : D S T 2 (Index) S O C 1 ÷ S O C 2 D S T 1 (Index) Remainder					
A N D	Logical AND [AND]	No	DST [Process. results transfer destination]	None	IX0000 ~ IX1999
			SOC 1 [Logical AND factor 1]	None	-99999999 ~ 99999999 IX0000 ~ IX1999
			SOC 2 [Logical AND factor 2]	None	-99999999 ~ 99999999 IX0000 ~ IX1999
			<ul style="list-style-type: none"> Executes AND and transfers the results to Index data. In case of Index data, a decimal point is neglected and numeric value is handled as integer for processing. (Sample: 1.25 is handled as 125 for processing.) Expression : D S T (Index) S O C 1 A N D S O C 2		

Title	Command name	B	Setting data		
			Data	Setting unit	Setting range (Direct data) (Index data)
		S	Function		
《Group 2 》 [Processing command]					
O R	Logical OR [OR]	No	DST [Process. results transfer destination]	None	IX0000 ~ IX1999
			SOC 1 [Logical OR factor1]	None	-99999999 ~ 99999999 IX0000 ~ IX1999
			SOC 2 [Logical OR factor2]	None	-99999999 ~ 99999999 IX0000 ~ IX1999
			<ul style="list-style-type: none"> Executes OR and transfers the results to Index data. In case of Index data, a decimal point is neglected and numeric value is handled as integer for processing. (Sample : 1.25 is handled as 125 for processing.) <p>Expression : D S T (I n d e x) S O C 1 O R S O C 2</p>		
X O R	Exclusive logical OR [eXclusive OR]	No	DST [Process. results transfer destination]	None	IX0000 ~ IX1999
			SOC 1 [Exclusive logical OR factor 1]	None	-99999999 ~ 99999999 IX0000 ~ IX1999
			SOC 2 [Exclusive logical OR factor 2]	None	-99999999 ~ 99999999 IX0000 ~ IX1999
			<ul style="list-style-type: none"> Executes Exclusive OR and transfers the results to Index data. In case of Index data, a decimal point is neglected and numeric value is handled as integer for processing. (Sample : 1.25 is handled as 125 for processing.) <p>Expression : D S T (I n d e x) S O C 1 X O R S O C 2</p>		

Title	Command name	B S	Setting data		
			Data	Setting unit	Setting range (Direct data) (Index data)
Function					
《Group 3 》 [Jump command]					
J M P	Un-conditional jump [JuMP]	Ys	JADR [Jump destination address]	None	000 ~ 279 IX0000 ~ IX1999
			• Jumps to specified address without any condition.		
J Z	0 Jump [Jump if Zero]	Ys	JADR [Jump destination address]	None	000 ~ 279 IX0000 ~ IX1999
			SOC [Branch condition decision data]	None	IX0000 ~ IX1999
			• Jumps to specified address when Branch decision is 0.		
J N Z	Not 0 Jump [Jump if Not Zero]	Ys	JADR [Jump destination address]	None	000 ~ 279 IX0000 ~ IX1999
			SOC [Branch condition decision data]	None	IX0000 ~ IX1999
			• Jumps to specified address when Branch decision is not 0.		
J G	Greater than 1 jump [Jump if Greater than zero]	Ys	JADR [Jump destination address]	None	000 ~ 279 IX0000 ~ IX1999
			SOC [Branch condition decision data]	None	IX0000 ~ IX1999
			• Jumps to specified address when Branch decision is 1 or more.		
J L	Less than - 1 jump [Jump if Less than zero]	Ys	JADR [Jump destination address]	None	000 ~ 279 IX0000 ~ IX1999
			SOC [Branch condition decision data]	None	IX0000 ~ IX1999
			• Jumps to specified address when Branch decision is - 1 or less .		

Title	Command name	B	Setting data		
			Data	Setting unit	Setting range (Direct data) (Index data)
		S	Function		
《Group 5 》 [Continuous motion command]					
S P N S	Spin speed [SPiN Speed]	No	RPM [Speed]	rpm	-9999 ~ 9999 IX0000 ~ IX1999
			TIME [Accel./ Decel.time]	0.01sec	000.00 ~ 655.35 IX0000 ~ IX1999
			M [M output]	None	00 ~ 99 IX0000 ~ IX1999
			<ul style="list-style-type: none"> • Achieves specified speed(rpm) for set Accel./Decel.time. But if Accel./ Decel.time setting exceeds the following stipulated max. value, Accel./ Decel.is conducted at the max. value, and the reached speed is constantly retained during excess time. Stipulated time : Max.Accel.time from 0 rpm to rated speed : 300.00 sec. Max.Decel.time from rated speed to 0 rpm. : 300.00 sec. • Can send M output at Motion start and wait for M completion . • When Hold (HLD) is inputted in executing this command, a motor decelerates and stops for [P214:Decel.time 1] and at restart M strobe signal output is OFF. 		
S P N T	Spin timer [SPiN Timer]	No	TIME [Retaining time]	0.01sec	000000.00 ~ 999999.99 IX0000 ~ IX1999
			M [M output]	None	00 ~ 99 IX0000 ~ IX1999
			<ul style="list-style-type: none"> • Retains speed status at Spin speed for specified time. • Can send M output at Motion start and wait for M completion . • When Hold (HLD) is inputted in executing this command, a motor decelerates and stops for [P214:Decel.time 1] and at restart M strobe signal output is OFF. 		
S P N P	Spin positioning [SPiN Positioning]	Ys	POS [Positioning position]	mm/ ° /in	00000000 ~ 99999999 IX0000 ~ IX1999
			DOWN [Decel. time selection]	None	SEL.1 / SEL.2 / SEL.3
			M [M output]	None	00 ~ 99 IX0000 ~ IX1999
			<ul style="list-style-type: none"> • Executes Positioning from rotating status at Spin speed to specified position for set time. • When Hold (HLD) is inputted in executing this command, a motor decelerates and stops for DOWN setting. 		

Title	Command name	B	Setting data		
			Data	Setting unit	Setting range (Direct data) (Index data)
		S	Function		
《Group 5 》 [Continuous motion command]					
S P O S	Positioning [Sequential POSitioning]	Ys	POS [Positioning position · direction]	mm/ ° /in	-99999999 ~ 99999999 IX0000 ~ IX1999
			A/I [Absolute position /Relative position]	None	ABSOLUTE / INCREMENT
			F [Positioning speed]	mm, ° ,in /sec	0000000 ~ 9999999 IX0000 ~ IX1999
			UPDN [Accel./Decel.time]	None	SEL.1 / SEL.2 / SEL.3
			TRG [External trigger position]	mm/ ° /in	00000000 ~ 99999999 IX0000 ~ IX1999
			OUT [General output]	Binary number	00000000 ~ 11111111 IX0000 ~ IX1999
			<ul style="list-style-type: none"> • Motion is identical to POS (Positioning) command. But next address is executed after motion is completed. 		
C O N T	Simple continuous Positioning [CONTinue positioning]	Ys	POS [Positioning position · direction]	mm/ ° /in	-99999999 ~ 99999999 IX0000 ~ IX1999
			A/I [Absolute position /Relative position]	None	ABSOLUTE / INCREMENT
			F [Positioning speed]	mm, ° ,in /sec	0000000 ~ 9999999 IX0000 ~ IX1999
			UPDN [Accel./Decel.time]	None	SEL.1 / SEL.2 / SEL.3
			TRG [External trigger position]	mm/ ° /in	00000000 ~ 99999999 IX0000 ~ IX1999
			OUT [General output]	Binary number	00000000 ~ 11111111 IX0000 ~ IX1999
			<ul style="list-style-type: none"> • When this command continues and motion direction is unchanged, Positioning is continued without stop. • When this command is single, function is same as SPOS. • External trigger positioning can be conducted. And External trigger positioning sets travel amount from TRG input. • General output can be sent when motion starts. • Accel./Decel.time and External trigger positioning in Continuous motion follows start block of this motion 'UPDN' and 'TRG'. 		

Title	Command name	B	Setting data		
			Data	Setting unit	Setting range (Direct data) (Index data)
		S	Function		
《Group 5 》 [Continuous motion command]					
R E P T	Repeat Positioning [REPeAT positioning]	Ys	POS [Positioning position · direction]	mm/ ° /in	-99999999 ~ 99999999 IX0000 ~ IX1999
			A/I [Absolute position /Relative position]	None	ABSOLUTE / INCREMENT
			F [Positioning speed]	mm, ° ,in /sec	0000000 ~ 9999999 IX0000 ~ IX1999
			UPDN [Accel./Decel.time]	None	SEL.1 / SEL.2 / SEL.3
			TRG [External trigger position]	mm/ ° /in	00000000 ~ 99999999 IX0000 ~ IX1999
			M [M output]	None	00 ~ 99 IX0000 ~ IX1999
			REPT [Looping time]	None	00000 ~ 65535 IX0000 ~ IX1999
S H O M	Zero return [Sequential HOME positioning]	Ys	Type [Zero return method]	None	STD.HOME / LS LESS / STOP HOME / OT HOME
			DIR [Motion direction]	None	FORWARD / REVERSE
			OUT [General output]	Binary number	00000000 ~ 11111111 IX0000 ~ IX1999
			<ul style="list-style-type: none"> • Motion is identical to 0 HOME (Zero return) command. But next address is executed after motion is completed. 		
S I N D	Index Positioning [Sequential INDeX positioning]	Ys	POS [Positioning position · direction]	mm/ ° /in	00000000 ~ 99999999 IX0000 ~ IX1999
			F [Positioning speed]	mm, ° ,in /sec	0000000 ~ 9999999 IX0000 ~ IX1999
			UPDN [Accel./Decel.time]	None	SEL.1 / SEL.2 / SEL.3
			OUT [General output]	Binary number	00000000 ~ 11111111 IX0000 ~ IX1999
			<ul style="list-style-type: none"> • Motion is identical to INDX (Index Positioning) command. Program is finished after motion is completed. 		

Title	Command name	B	Setting data		
			Data	Setting unit	Setting range (Direct data) (Index data)
		S	Function		
《Group 4 》 [Driver command]					
T R Q	Torque control [ToRQue]	Ys	TRQ [Torque command selection]	None	SEL0 ~ SEL3
			M [M output]	None	00 ~ 99 IX0000 ~ IX1999
			<ul style="list-style-type: none"> • Executes Torque control in accordance with Torque command selection. • When 「SEL0」 is selected by Torque command selection, motion is conducted by External torque command • When 「SEL1~3」 is selected by Torque command selection, motion is conducted by parameters [P136~P138: Torque command 1~3]. • Sends M output at Motion start and becomes Complete motion by M completion (MFIN) input. • Complete motion conducts Servo lock after Decel.stop and executes next command. • When Hold (HLD) is inputted in executing this command, a motor decelerates and stops. • Decel. stop at Complete motion and Hold (HLD) is conducted by [P216: Decel. time 3]. 		
S P D	Speed control [SPeeD]	Ys	SPD [Speed command selection]	None	SEL0 ~ SEL7
			M [M output]	None	00 ~ 99 IX0000 ~ IX1999
			<ul style="list-style-type: none"> • Executes Speed control in accordance with Speed command selection. • When 「SEL0」 is selected by Speed command selection, motion is conducted by External speed command • When 「SEL1~7」 is selected by Speed command selection, motion is conducted by parameters [P129~P135: Speed command 1~7]. • Accel./ Decel. is conducted by [P213: Accel.time 3], [P216: Decel. time 3]. • Sends M output at Motion start and becomes Complete motion by M completion (MFIN) input. • Complete motion conducts Servo lock after Decel.stop and executes next command. • When Hold (HLD) is inputted in executing this command, a motor decelerates and stops. • Decel. stop at Complete motion and Hold (HLD) is conducted in accordance with [P216: Decel. time 3]. 		

Supplement of Command specification description

BS column indicates Block stop function at each command end.
 (Block stop function executes stop motion at command end by Block stop signal (BTSP) in Auto. run.)

- 「No」 neglects Block stop signal and executes next address command.
- 「No」 neglects Block stop signal and executes commands to Program end.
- 「Ys」 makes wait condition for restart when a command is completed.
Next address command is executed by restart.
- 「Ys」 makes wait condition for restart when Continuous motion is completed and a motor stops.
Next address command of Block stop completion is executed by restart.
- 「Ys」 makes wait condition for restart when all the Repeat positioning is completed.
Next address command is executed by restart.
- 「Ys」 makes wait condition for restart after calling specified address.
Specified address command is executed by restart and this command is continued or restarted.

Cautions common to commands

Caution 1) Program run is terminated by input of one of 「POS」 / 「HOME」 / 「INDX」 / 「PEND」 commands.

Caution 2) Available range of General output and M output depends on a controller type.

Controller type	Local control output (connector:J5)	Serial communication (connector:J1)	Sequence control (aux. relay M)	Remote sequence control (output relay X)
NCS-FI/FS10	No	Yes	No	No
NCS-FI/FS12	Yes 1	Yes	No	No
NCS-FI/FS13	No	Yes	No	Yes 2
NCS-FI/FS22	No	Yes	Yes 2	No
NCS-FI/FS23	No	Yes	Yes 2	No

Yes : Either General outputs or M outputs can be outputted externally.

Yes : All of General outputs and M outputs can be outputted remotely.

No : General outputs and M outputs can not be outputted.

1 : OUT or M output of Local control output may not be conducted by the parameter [P717: Output signal function selection 1] setting.
Description can be referred to 「3-3 Parameter specification」.

2 : External output can be conducted by sequence program.

Caution 3) More detailed specification than this manual can be referred to the separate manual 『Volume: Command』.

5 - 4 Driver command description

5 - 4 - 1 【TRQ】 Torque control

「Function」

△ This command executes Torque control which has next function.

(Next address command is executed after this command is completed.)

Torque control is executed in accordance with Torque command selection.

When 「SEL0」 is selected by Torque command selection, motion is conducted by External torque command (TQH).

When 「SEL1~3」 is selected by Torque command selection, motion is conducted by parameters [P136~P138:Torque command value 1~3].

M output is sent at this command start and Complete motion is achieved by M completion input (MFIN).

Complete motion conducts Servo lock after Decel. stop and executes next command.

When Hold (HLD) is inputted in executing this command, deceleration stop is conducted and then Servo lock works.

Decel.stop at Complete motion and Hold (HLD) are conducted for [P216:Decel.time 3].

When restart is conducted after Hold (HLD) is executed, Torque control continues. However if M complete is inputted in executing Hold (HLD), this command will be completed at restart.

Torque limit value can be changed by Torque limit signal (TL) in executing this command.

Positioning complete signal (PN) and Rough matching signal (PRF) is OFF at this command start.

Relation of Speed limit command and motor max. speed.

- In order to depress motor speed increase at light load, etc. in Torque control, motor max. speed can be limited.
- Limit value is lower value of External speed limit command (common to External speed command (INH) value and the parameter P128 「Speed limit value」.
- Motor max. speed is proportional to External speed limit command value and rated speed at DC+10V input.
- External speed limit command and P128 「Speed limit value」 is common set for both forward and reverse directions.
- Enable / Disable of External speed limit command can be selected by the parameter P127 「External speed limit command enable/ disable selection」.

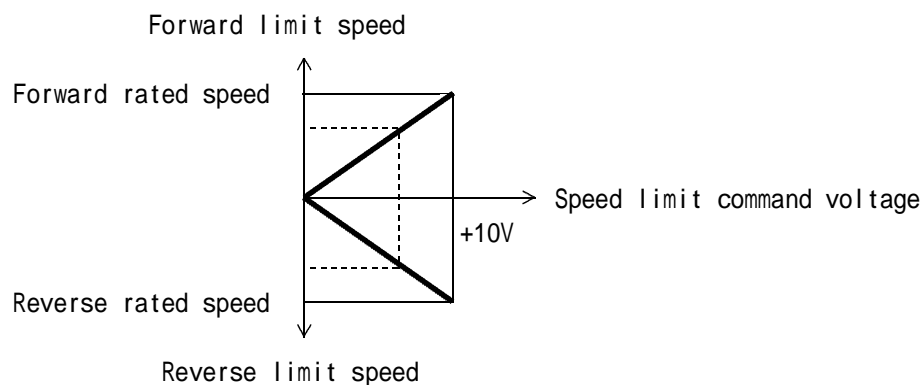

[Fig. 5 - 1] Relation of Speed limit command and motor speed

Relation of External torque command and Motor output torque

- Motor output torque is proportional to External Torque command voltage and 300% output torque at DC $\pm 10V$ input. (When rated torque is 100%.)
- By positive External torque command voltage, a motor generates forward output torque.
- By negative External torque command voltage, a motor generates reverse output torque.

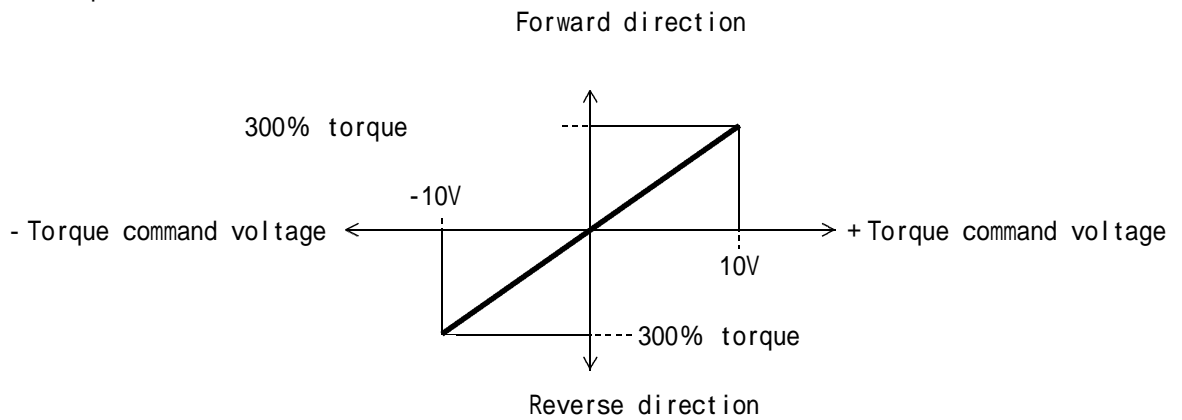

[Fig. 5 - 2] Relation of External Torque command and Motor output torque

『Setting』

Title display	Setting contents		
Display sequence	Setting unit	Setting range (Direct data) (Index data)	Initial value
	Reference (Details and supplement of Setting description)		

《Group 4 : T R Q》

T R Q P P	Torque command selection												
	None	SEL.0 ~ SEL.3	SEL.0										
	⚠SEL.0~SEL.3 of Torque command <table border="1" style="margin-left: 20px;"> <thead> <tr> <th>Torque command selection</th> <th>Torque command value</th> </tr> </thead> <tbody> <tr> <td>SEL.0</td> <td>External torque command (TQH signal)</td> </tr> <tr> <td>SEL.1</td> <td>Parameter [P136:Torque command value1]</td> </tr> <tr> <td>SEL.2</td> <td>Parameter [P137:Torque command value2]</td> </tr> <tr> <td>SEL.3</td> <td>Parameter [P138:Torque command value3]</td> </tr> </tbody> </table>			Torque command selection	Torque command value	SEL.0	External torque command (TQH signal)	SEL.1	Parameter [P136:Torque command value1]	SEL.2	Parameter [P137:Torque command value2]	SEL.3	Parameter [P138:Torque command value3]
Torque command selection	Torque command value												
SEL.0	External torque command (TQH signal)												
SEL.1	Parameter [P136:Torque command value1]												
SEL.2	Parameter [P137:Torque command value2]												
SEL.3	Parameter [P138:Torque command value3]												
M P	M output data												
	Bcd 2 digits	00 ~ 99 IX0000 ~ IX1999	/00										
	⚠When M output data are disabled, M output data are not sent but M strobe (MSTB) is ON and M completion is waited.												

『Motion sample』

《Torque control motion sample》

ADDR	CMD	TRQ	M			Reference
001	TRQ	SEL.0	25			
002	TRQ	SEL.2	33			
003	PEND	-----	-----			

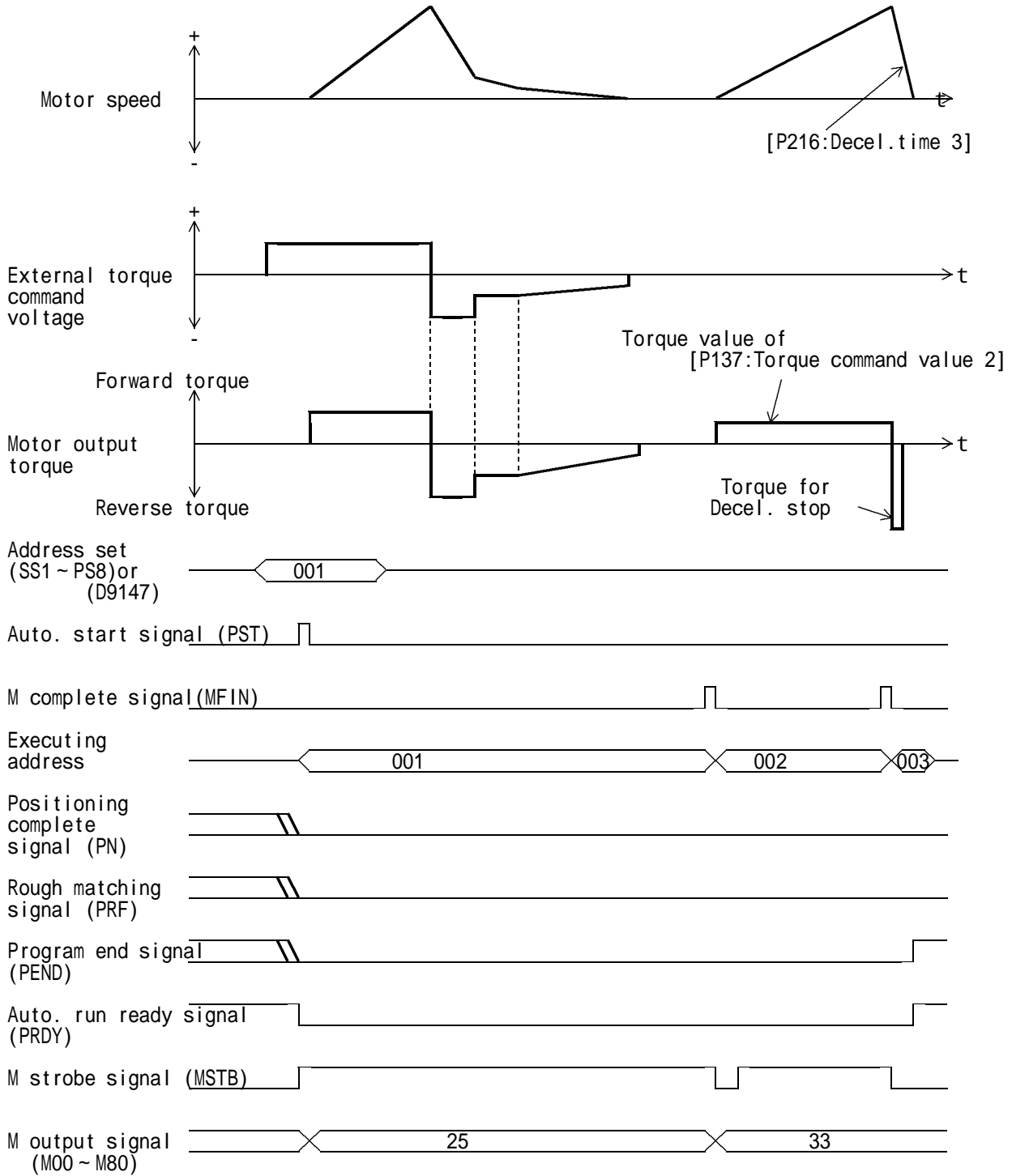

5 - 4 - 2 【SPD】 Speed control

『Function』

△ This command executes Speed control which has next function.
(Next address command is executed after this command is completed.)

Speed control is executed in accordance with Speed command selection.

When 「SEL0」 is selected by Speed command selection, motion is conducted by External Speed command (INH).

When 「SEL1~7」 is selected by Speed command selection, motion is conducted by parameters [P129~P135:Speed command value 1~7].

M output is sent at motion start and Complete motion is achieved by M completion input (MFIN).
Complete motion conducts Servo lock after Decel. stop and executes next command.

When Hold (HLD) is inputted in executing this command, deceleration stop is conducted.

Decel.stop at Complete motion and Hold (HLD) are conducted for [P216:Decel.time 3].

When restart is conducted after Hold (HLD) is executed, Speed control continues. However if M complete is inputted in executing Hold (HLD), this command will be completed at restart.

Positioning complete signal (PN) and Rough matching signal (PRF) are OFF at this command start.

Accel./ Decel time in Speed control is determined by parameters [P213: Accel. time 3] and [P216:Decel.time 3].

When 「SEL1~7」 is selected by Speed limit command selection and motion is conducted, Override (OR1~OR4) is effective to Speed command value in real time.. For instance, when Override is set 70% to Speed command value 1000 rpm, motor speed is 700 rpm.

Relation of External speed command and Motor speed

- Motor speed is proportional to External speed command voltage and is rated speed at DC $\pm 10V$ input.

And by the parameter P124 「Speed command gain」, Speed command voltage to rated speed can be set at DC $\pm 6V \sim \pm 10V$ input.

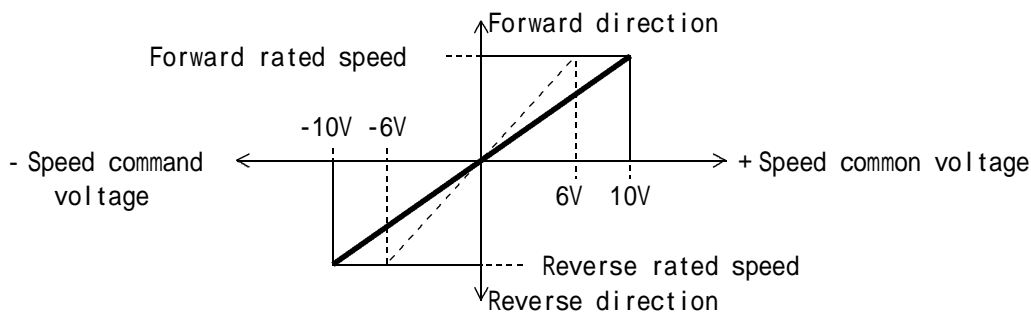

[Fig. 5 - 3] Relation of External Speed command and motor speed

『Setting』

Title display		Setting contents	
Display sequence	Setting unit	Setting range (Direct data) (Index data)	Initial value
	Reference (Details and supplement of Setting description)		

《Group 4 : S P D》

S P D P P		Speed command selection																			
<p>△SEL.0 ~ SEL.7 of Speed command</p> <table border="1"> <thead> <tr> <th>Speed command selection</th> <th>Speed command value</th> </tr> </thead> <tbody> <tr> <td>SEL.0</td> <td>External Speed command (INH signal)</td> </tr> <tr> <td>SEL.1</td> <td>Parameter [P129:Speed command value 1]</td> </tr> <tr> <td>SEL.2</td> <td>Parameter [P130:Speed command value 2]</td> </tr> <tr> <td>SEL.3</td> <td>Parameter [P131:Speed command value 3]</td> </tr> <tr> <td>SEL.4</td> <td>Parameter [P132:Speed command value 4]</td> </tr> <tr> <td>SEL.5</td> <td>Parameter [P133:Speed command value 5]</td> </tr> <tr> <td>SEL.6</td> <td>Parameter [P134:Speed command value 6]</td> </tr> <tr> <td>SEL.7</td> <td>Parameter [P135:Speed command value 7]</td> </tr> </tbody> </table>	Speed command selection	Speed command value	SEL.0	External Speed command (INH signal)	SEL.1	Parameter [P129:Speed command value 1]	SEL.2	Parameter [P130:Speed command value 2]	SEL.3	Parameter [P131:Speed command value 3]	SEL.4	Parameter [P132:Speed command value 4]	SEL.5	Parameter [P133:Speed command value 5]	SEL.6	Parameter [P134:Speed command value 6]	SEL.7	Parameter [P135:Speed command value 7]	None	SEL.0 ~ SEL.7	SEL.0
	Speed command selection	Speed command value																			
	SEL.0	External Speed command (INH signal)																			
	SEL.1	Parameter [P129:Speed command value 1]																			
	SEL.2	Parameter [P130:Speed command value 2]																			
	SEL.3	Parameter [P131:Speed command value 3]																			
	SEL.4	Parameter [P132:Speed command value 4]																			
	SEL.5	Parameter [P133:Speed command value 5]																			
	SEL.6	Parameter [P134:Speed command value 6]																			
	SEL.7	Parameter [P135:Speed command value 7]																			
M P		M output data																			
	BCD 2 digits	00 ~ 99 IX0000 ~ IX1999	/00																		
	△When M output data are disabled, M output data are not sent but M strobe (MSTB) is ON and M completion is waited.																				

『Motion sample』

《Speed control motion sample》

ADDR	CMD	TRQ	M			Reference
001	SPD	SEL.0	38			
002	SPD	SEL.5	95			
003	PEND	-----	-----			

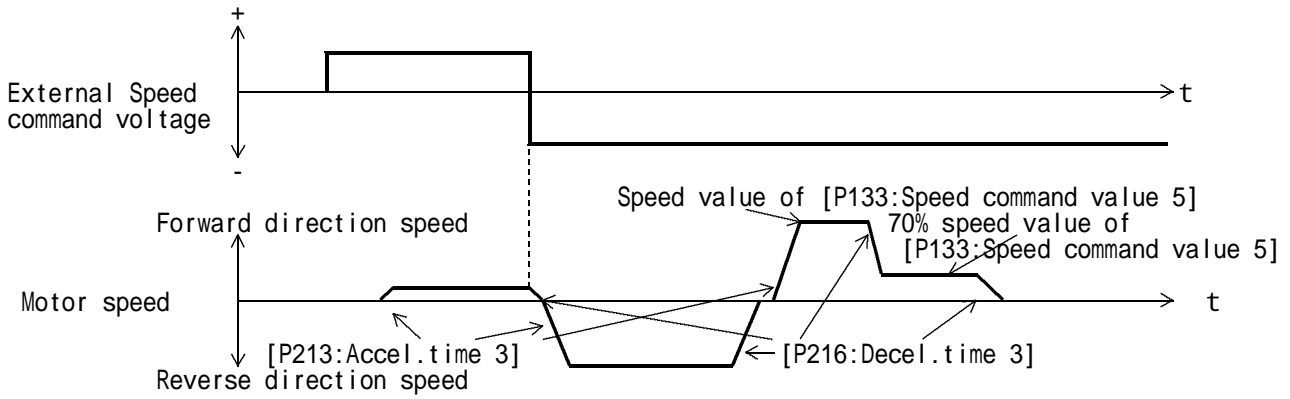

Address set (SS1 ~ PS8) or (D9147) 001

Auto. start signal (PST)

M complete signal (MFIN)

Override signal (OR1 ~ OR4) 80% 100% 70%
 Executing address 001 002 003

Positioning complete signal (PN)

Rough matching signal (PRF)

Program end signal (PEND)

Auto. run ready signal (PRDY)

M strobe signal (MSTB)

M output signal (MOO ~ M80) 38 95

5 - 5 Driver command format

Driver command format in communication is described.

And as for 「commands other than Driver」, please refer to the separate manual 『Volume : Communication protocol』.

Device No. corresponding to each Command data item starts first device No. of the specified Command data address.

< Sample >

When Command data address is 「0」, first device is 「R0800」 and following Command data device is { [First]+0=R0800 } ~ { [First]+9=R0809 } .

In the below tabulation, Command data address = 「0」 and [First]=R0800 are introduced as a sample.

[Torque control command (TRQ)]

Device No. (sample)	Device	(bit) Item															
		F	E	D	C	B	A	9	8	7	6	5	4	3	2	1	0
R0800	[First]+0	Command code:40H								Index set flag Bit (0:Direct, 1:Index) 3 : DT3 Direct/ Index set Set 0 for other than above.							
R0801	[First]+1	DT5 : Set 0. (Un-used)				DT6 : Torque command selec. 0:SEL0 1:SEL1 2:SEL2 3:SEL3				DT7 : Set 0. (Un-used)				DT8 : M output 0: Disable 1: Enable			
R0802	[First]+2	DT0 : Set 0. (Un-used)															
R0803	[First]+3	High order data ----- Low order data															
R0804	[First]+4	DT1 : Set 0. (Un-used)															
R0805	[First]+5	High order data ----- Low order data															
R0806	[First]+6	DT2 : Set 0. (Un-used)															
R0807	[First]+7	High order data ----- Low order data															
R0808	[First]+8	DT3 : M output data (Only bits 0~7 are used.)															
R0809	[First]+9	DT4 : Set 0. (Un-used)															

[Tab. 5 - 3] Torque control command (TRQ) data type

[Speed control command (S P D)]

Device No. (sample)	Device	(bit) Item															
		F	E	D	C	B	A	9	8	7	6	5	4	3	2	1	0
R0800	[First]+0	Command code : 41H										Index set flag Bit (0:Direct, 1:Index) 3 : DT3 Direct/ Index set Set 0 for other than above.					
R0801	[First]+1	DT5 : Set 0. (Un-used)				DT6 : Speed command selec. 0:SEL0, 4:SEL4 1:SEL1, 5:SEL5 2:SEL2, 6:SEL6 3:SEL3, 7:SEL7				DT7 : Set 0. (Un-used)				DT8 : M output 0 : Disable 1 : Enable			
R0802	[First]+2	DT0 : Set 0. (Un-used)															
R0803	[First]+3	High order data ----- Low order data															
R0804	[First]+4	DT1 : Set 0. (Un-used)															
R0805	[First]+5	High order data ----- Low order data															
R0806	[First]+6	DT2 : Set 0. (Un-used)															
R0807	[First]+7	High order data ----- Low order data															
R0808	[First]+8	DT3 : M output data (Only bits 0~7 are used.)															
R0809	[First]+9	DT4: Set 0. (Un-used)															

[Tab. 5 - 4] Speed data command (SPD) data type

Chapter 6 Protective function

6 - 1 Protective function and error treatment

The controller has various Protective function to prevent a controller or a motor from damage, and Error treatment function to inform operation error, etc. .
Protective function consists of 「Alarm treatment」 and 「Warning treatment」
And Error treatment function has 「Error display」.

Alarm treatment

when an error is detected, a motor stops (sudden stop or Torque free based on an error type) and Alarm signal output and Alarm message display are conducted, simultaneously.

Warning treatment

If it is supposed to probably become error if current operation is continued, Warning of error notice will be made.

The controller outputs Warning signal when Warning occurs and display Warning message but does not stop motor motion.

Error display

When operation error, input error, etc. occurs, Error message is displayed on the spot.

	Treatment description when Error occurs (detected).		
	Motor motion status	Control out. signal	LCD display
Alarm treat	Sudden stop or Torque free	Alarm signal ON	Alarm message
Warning treat.	Current motion continues.	Warning signal ON	Warning message
Error display	Current motion continues.	Un-changed	Error message

[Tab. 6 - 1] Error occurrence and treatment

6 - 2 Protective function list

6 - 2 - 1 Alarm list

Name ----- Display	Contents	Motion and output signal status	Way to release
IPM error ----- ALM. P IPM ERR.	Due to line-to-ground of motor or same and short-circuit of U,V,W cables between controller and motor over-current flows in main circuit transistor or cooling heat sink for power element is over-heated.	Motor torque free. Alarm ON Warning OFF Servo ready OFF Brake release OFF	Power reinput Reset signal (RST) input
Control power under voltage error ----- ALM. P UNDRVOLT1	Control power (+5V, +15V) voltage dropped. DC+5V : About +4.75V or less DC+15V : About +13.5V or less	Motor torque free Alarm ON Warning OFF Servo ready OFF Brake release OFF	Power reinput Reset signal (RST) input
Main power source under voltage error ----- ALM. P UNDRVOLT2	Main circuit DC bus voltage dropped less than 180[370]V. In [], value of 400V type (In case of controller combined with main power type detects Alarm.)	Motor stops and torq. free by [P713]. Alarm ON Warning OFF Servo ready OFF Brake release OFF	Power reinput Reset signal (RST) input
Over-voltage error ----- ALM. P OVER P VOLT	Due to excess load inertia, etc. at motor stop or decel. regenerative energy is beyond capacity and DC power voltage of main circuit exceeds about 400 [820]V. In [], value of 400V type	Motor torque free Alarm ON Warning OFF Servo ready OFF Brake release OFF	Power reinput Reset signal (RST) input
Motor over-heat error ----- ALM. P OVERHEAT2	Motor temp. detection thermister is 150 or more.	Motor torque free Alarm ON Warning OFF Servo ready OFF Brake release OFF	Wait until motor becomes cool, then Power reinput Reset signal (RST) input
Disconnection of thermister ----- ALM. P THERMIST.	Cable of motor temp. detection thermister is broken or disconnected.	Motor torque free Alarm ON Warning OFF Servo ready OFF Brake release OFF	Confirm wiring, then Power reinput Reset signal (RST) input
Encoder fault ----- ALM. P P ENCODER	Encoder fault Disconnect. or break of encoder cable or loose fitness of connector. Wrong encoder selection by parameter, etc. occurred.	Motor torque free Alarm ON Warning OFF Servo ready OFF Brake release OFF	Confirm encoder, encoder cable and parameter 「P001」, then Power reinput

[Tab. 6 - 2 (a)] Alarm list 1/9

Name ----- Display	Contents	Motion and output signal status	Way to release
Motor shaft error at ----- <div style="border: 1px solid black; padding: 5px; width: fit-content; margin: 0 auto;"> ALM. PW. ON ENC </div> power input	Motor shaft has been rotated or vibrated when power is turned ON. In the case, encoder can not be initialized. 【Detection only for NCS-FS type】	Motor torque free Alarm ON Warning OFF Servo ready OFF	Power reinput
Overspeed error ----- <div style="border: 1px solid black; padding: 5px; width: fit-content; margin: 0 auto;"> ALM. OVERSPEED </div>	Motor speed is more than about 130 % of rated speed.	Motor torque free Alarm ON Warning OFF Servo ready OFF Brake release OFF	Power reinput Reset signal (RST) input
Over-load error ----- <div style="border: 1px solid black; padding: 5px; width: fit-content; margin: 0 auto;"> ALM. OVER LOAD </div>	Due to over-load, or too frequent ON/OFF than allowable times, internal electric thermal is activated.	Motor torque free Alarm ON Warning OFF Servo ready OFF Brake release OFF	Power reinput Reset signal (RST) input
AC loss detection error ----- <div style="border: 1px solid black; padding: 5px; width: fit-content; margin: 0 auto;"> ALM. AC DOWN </div>	AC power voltage dropped less than about 145[290] V for 50ms or more. (Black out occurred.) In [], value of 400V type	Motor stops and torque free by[P713]. Alarm ON Warning OFF Servo ready OFF Brake release OFF	Power reinput Reset signal (RST) input
Deviation over-flow ----- <div style="border: 1px solid black; padding: 5px; width: fit-content; margin: 0 auto;"> ALM. OVERFLOW </div>	Position deviation exceeds setting value of [P207: Over-flow detection pulse].	Sudden motor stop and torq. free Alarm ON Warning OFF Servo ready OFF Brake release OFF	Power reinput Reset signal (RST) input
Deviation error ----- <div style="border: 1px solid black; padding: 5px; width: fit-content; margin: 0 auto;"> ALM. VARI. OVER </div>	Position deviation exceeds setting of [P208: Deviation error detection pulse]. But it is applied when 「STOP: Alarm stop」 is selected by [P209: Motion selection at Deviation error].	Sudden motor stop and Servo lock Alarm ON Warning OFF Servo ready ON *1 Brake release ON	Power reinput Reset signal (RST) input

*1: Status when 「RDY1」 is selected by [P716: RDY signal spec. selection].
If other is selected, status could be different.

[Tab. 6 - 2 (b)] Alarm list 2/9

Name Display	Contents	Motion and output signal status	Way to release
Forward over travel <hr style="border-top: 1px dashed black;"/> <div style="border: 1px solid black; padding: 5px; width: fit-content; margin: 0 auto;"> ALM. P + HARD POT. </div>	Forward over travel signal(FOT) is detected.	Sudden motor stop and Servo lock Alarm ON Warning OFF Servo ready ON *1 Brake release ON	Motor moves to reverse by Jog motion and release forward over-travel.
Reverse over travel <hr style="border-top: 1px dashed black;"/> <div style="border: 1px solid black; padding: 5px; width: fit-content; margin: 0 auto;"> ALM. P - HARD POT. </div>	Reverse over travel signal(ROT) is detected.	Sudden motor stop and Servo lock Alarm ON Warning OFF Servo ready ON *1 Brake release ON	Motor moves to forward by Jog motion and release reverse over-travel.
Forward software over travel <hr style="border-top: 1px dashed black;"/> <div style="border: 1px solid black; padding: 5px; width: fit-content; margin: 0 auto;"> ALM. P + SOFT POT. </div>	Current position exceeds setting value of [P306 : Forward software OT limit] .	Sudden motor stop and Servo lock Alarm ON Warning OFF Servo ready ON *1 Brake release ON	Motor moves to reverse travel limit by Jog motion.
Reverse software over travel <hr style="border-top: 1px dashed black;"/> <div style="border: 1px solid black; padding: 5px; width: fit-content; margin: 0 auto;"> ALM. P - SOFT POT. </div>	Current position exceeds setting value of [P307 : Reverse software OT limit] .	Sudden motor stop and Servo lock Alarm ON Warning OFF Servo ready ON *1 Brake release ON	Motor moves to forward travel limit by Jog motion.

*1 : Status when 「RDY1」 is selected by [P716: RDY signal spec. selection] .
 If other is selected, status could be different.

[Tab. 6 - 2 (c)] Alarm list 3/9

Name ----- Display	Contents	Motion and output signal status	Way to release
No set of motor type ----- ALM. P MOTR TYPE 1	Setting of [P000: Motor type] is 「000」.	Motor torque free Alarm ON Warning OFF Servo ready OFF Brake release OFF	Set motor type, then Power reinput
Motor type error ----- ALM. P MOTR TYPE 2	Combination of motor and controller selected by [P000: Motor type] is wrong.	Motor torque free Alarm ON Warning OFF Servo ready OFF Brake release OFF	Set motor type correctly, then Power reinput
Extended memory cell under voltage error ----- ALM. P RAM BATT.	Voltage of data hold cell for extended memory (option) dropped. (Only once, Alarm is outputted in power ON status.)	Motor torque free Alarm ON Warning OFF Servo ready OFF Brake release OFF	Reset signal (RST) input. Immediate replacement of extended memory by us is required.
EEPROM (nan-volatile) write error ----- ALM. P WR. EEPROM	Write of data to EEPROM (in controller) was failed.	Sudden motor stop and Servo lock Alarm ON Warning OFF Servo ready ON *1 Brake release ON	Power reinput Reset signal (RST) input
Rated speed command error 1 ----- ALM. P STD. SPD. 1	Speed at motor rated speed set by [P303,P304: Electric gear ratio] and [P310: Machine travel amount] exceeds 2M (setting unit / sec).	Motor torque free Alarm ON Warning OFF Servo ready OFF Brake release OFF	Correct [P303, P304: Electric gear ratio] and [P310: Machine travel amount], then Power reinput Reset signal (RST) input
Rated speed command error 2 ----- ALM. P STD. SPD. 2	Speed at motor rated speed set by [P303,P304: Electric gear ratio] and [P310: Machine travel amount] is less than 100mm (setting unit / sec).	Motor torque free Alarm ON Warning OFF Servo ready OFF Brake release OFF	Correct [P303, P304: Electric gear ratio] and [P310: Machine travel amount], then Power reinput Reset signal (RST) input
Address set error ----- ALM. P ADDR ERR.	Command out of 0~279 range was specified and tried.	Motor servo lock Alarm ON Warning OFF Servo ready ON *1 Brake release ON	Correct to right address, then Power reinput Reset signal (RST) input

*1: Status when 「RDY1」 is selected by [P716: RDY signal spec. selection].
If other is selected, status could be different.

[Tab. 6 - 2 (d)] Alarm list 4/9

Name ----- Display	Contents	Motion and output signal status	Way to release
Positioning time over ----- ALM. P PTIME POUT	Positioning is not completed after set time [P203: Positioning time over] passed.	A motor sudden stops and in servo lock. Alarm ON Warning OFF Servo ready ON *1 Brake release ON	Power reinput Reset signal (RST) input
Positioning data over-flow ----- ALM. P DATA P OVER	Simple continuous positioning is tried to execute continuous travel distance out of range 2147483647 ~ -2147483647.	Motor in servo lock Alarm ON Warning OFF Servo ready ON *1 Brake release ON	Set continuous travel distance in the range. Power reinput Reset signal (RST) input
No 1 rotation data set error ----- ALM. P P305 P ERR.	Without setting of [P305: Index positioning range], i.e. 「0」, Index positioning or Spin command is tried to execute.	Motor in servo lock Alarm ON Warning OFF Servo ready ON *1 Brake release ON	Set [P305: Index positioning range] correctly, then, Power reinput Reset signal (RST) input
No program end command set error ----- ALM. P PEND. ERR.	In executing command other than 0, address becomes 280 due to no PEND command set.	A motor sudden stops and in servo lock. Alarm ON Warning OFF Servo ready ON *1 Brake release ON	Input correct program, then, Power reinput Reset signal (RST) input
Subroutine call nesting over ----- ALM. P CALL P OVER	Subroutine call is tried to execute 9 times without executing Subroutine return.	Motor in servo lock Alarm ON Warning OFF Servo ready ON *1 Brake release ON	Input correct program, then, Power reinput Reset signal (RST) input
Subroutine return error ----- ALM. P PRET P ERR.	Subroutine call is tried to execute without executing Subroutine return.	Motor in servo lock Alarm ON Warning OFF Servo ready ON *1 Brake release ON	Input correct program, then, Power reinput Reset signal (RST) input

*1: Status when 「RDY1」 is selected by [P716: RDY signal spec. selection].
If other is selected, status could be different.

[Tab. 6 - 2 (e)] Alarm list 5/9

Name ----- Display	Contents	Motion and output signal status	Way to release
Jump address error ----- ALM. P JUMP P ERR.	Jump to address or Subroutine addresses is set other than range 0~278 and was tried to execute the command.	Motor in servo lock Alarm ON Warning OFF Servo ready ON *1 Brake release ON	Input correct address, then, Power reinput Reset signal (RST) input
Spin command error ----- ALM. P SPN. ERR.	Without executing SPNS command, SPNT or SPNP is tried to execute. Or in Spinning, command other than SPNS, SPNT, SPNP is tried to execute. Or, SPNS or SPNT is executed by Address 279.	A motor sudden stops and in servo lock. Alarm ON Warning OFF Servo ready ON *1 Brake release ON	Input correct program, then Power reinput Reset signal (RST) input
Division error ----- ALM. P ODIV. ERR.	「0」 is tried to execute as divisor.	Motor in servo lock Alarm ON Warning OFF Servo ready ON *1 Brake release ON	Input correct divisor, then Power reinput Reset signal (RST) input
Positioning amount error ----- ALM. P POS P OVER	Positioning command is tried to execute by the setting over Parameter [P308: Max. Forward positioning amount] or [P309: Max. Reverse positioning amount].	Motor in servo lock Alarm ON Warning OFF Servo ready ON *1 Brake release ON	Input correct data, then, Power reinput Reset signal (RST) input
Error command ----- ALM. P CMND. ERR.	Command which can not be identified is tried to execute. (It occurs when an error command is registered by communication)	Motor in servo lock Alarm ON Warning OFF Servo ready ON *1 Brake release ON	Input correct data, then, Power reinput Reset signal (RST) input
Index data error ----- ALM. P IXNO. ERR.	Command specified Index data No. out of 0~999 is tried to execute. (It occurs when Index data offset No. is used or error index data No. is registered by communication.)	Motor in servo lock Alarm ON Warning OFF Servo ready ON *1 Brake release ON	Input correct data, then, Power reinput Reset signal (RST) input

*1: Status when 「RDY1」 is selected by [P716: RDY signal spec. selection].
If other is selected, status could be different.

[Tab. 6 - 2 (f)] Alarm list 6/9

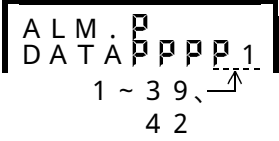









Name ----- Display	Contents	Motion and output signal status	Way to release
Stored data error 1 ~ 39, 42 	Stored data are broken.	Motor in torq. free Alarm ON Warning OFF Servo ready OFF Brake release OFF	Reset data, then Power reinput Reset signal (RST) input But since DATA39 error release is impossible, consult us.

Display	Description
DATA P P P P 1	Parameter data (Group0 / P000 ~ 99) were broken.
DATA P P P P 2	Parameter data (Group1 / P100 ~ 199) were broken.
DATA P P P P 3	Parameter data (Group2 / P200 ~ 299) were broken.
DATA P P P P 4	Parameter data (Group3 / P300 ~ 399) were broken.
DATA P P P P 5	Parameter data (Group4 / P400 ~ 499) were broken.
DATA P P P P 6	Parameter data (Group5 / P500 ~ 599) were broken.
DATA P P P P 7	Parameter data (Group6 / P600 ~ 699) were broken.
DATA P P P P 8	Parameter data (Group7 / P700 ~ 799) were broken.
DATA P P P P 9	Command data (Address 000 ~ 009) were broken.
DATA P P P P 10	Command data (Address 010 ~ 019) were broken.
DATA P P P P 11	Command data (Address 020 ~ 029) were broken.
DATA P P P P 12	Command data (Address 030 ~ 039) were broken.
DATA P P P P 13	Command data (Address 040 ~ 049) were broken.
DATA P P P P 14	Command data (Address 050 ~ 059) were broken.
DATA P P P P 15	Command data (Address 060 ~ 069) were broken.
DATA P P P P 16	Command data (Address 070 ~ 079) were broken.
DATA P P P P 17	Command data (Address 080 ~ 089) were broken.
DATA P P P P 18	Command data (Address 090 ~ 099) were broken.
DATA P P P P 19	Command data (Address 100 ~ 109) were broken.
DATA P P P P 20	Command data (Address 110 ~ 119) were broken.
DATA P P P P 21	Command data (Address 120 ~ 129) were broken.
DATA P P P P 22	Command data (Address 130 ~ 139) were broken.
DATA P P P P 23	Command data (Address 140 ~ 149) were broken.
DATA P P P P 24	Command data (Address 150 ~ 159) were broken.
DATA P P P P 25	Command data (Address 160 ~ 169) were broken.
DATA P P P P 26	Command data (Address 170 ~ 179) were broken.
DATA P P P P 27	Command data (Address 180 ~ 189) were broken.
DATA P P P P 28	Command data (Address 190 ~ 199) were broken.
DATA P P P P 29	Command data (Address 200 ~ 209) were broken.
DATA P P P P 30	Command data (Address 210 ~ 219) were broken.
DATA P P P P 31	Command data (Address 220 ~ 229) were broken.
DATA P P P P 32	Command data (Address 230 ~ 239) were broken.
DATA P P P P 33	Command data (Address 240 ~ 249) were broken.
DATA P P P P 34	Command data (Address 250 ~ 259) were broken.
DATA P P P P 35	Command data (Address 260 ~ 269) were broken.
DATA P P P P 36	Command data (Address 270 ~ 279) were broken.
DATA P P P P 37	Index data (IX00 ~ IX49) were broken.
DATA P P P P 39	Adjustment data for unit shipment were broken.
DATA P P P P 42	Index data (IX100 ~ IX999) were broken. Only units equipped with extended memory can detect.

[Tab. 6 - 2 (g)] Alarm list 7/9

Name ----- Display	Contents	Motion and output signal status	Way to release
Absolute encoder preload error ----- ALM . P ABS . PRE . L	Preload is not completed after preload of Absolute encoder works. Applied when Absolute encoder is used.	Motor in servo lock Alarm ON Warning OFF Servo ready ON Brake released OFF	Power reinput Reset signal (RST) input
Absolute encoder battery error ----- ALM . P ABS . BATT .	External battery voltage for Absolute encoder data back up dropped. Detected when power is turned ON. Applied when Absolute	Motor in torq. free Alarm ON Warning OFF Servo ready OFF Brake release OFF	Replace external battery, then, Power reinput Reset signal (RST) input
Absolute encoder count error ----- ALM . P ABS . COUNT	Counter error of Absolute encoder occurs. Applied when Absolute encoder is used.	Motor in torq. free Alarm ON Warning OFF Servo ready OFF Brake release OFF	Power reinput Reset signal (RST) input
Absolute encoder over-flow error ----- ALM . P ABS . OVER	Rotating amount of Absolute encoder is more than ± 4095 turns. Applied when Absolute encoder is used.	Motor in torq. free Alarm ON Warning OFF Servo ready OFF Brake release OFF	Power reinput Reset signal (RST) input Initialize sett- ing of Absolute encoder.
Absolute encoder data back up error ----- ALM . P ABS . BAKUP	Absolute position data backed up in Absolute encoder is gone. Applied when Absolute encoder is used.	Motor in torq. free Alarm ON Warning OFF Servo ready OFF Brake release OFF	Power reinput Reset signal (RST) input Initialize sett- ing of Absolute encoder.
Absolute encoder communication error ----- ALM . P ABS . COMM .	Data Absolute encoder can not be received. Applied when Absolute encoder is used.	Motor in torq. free Alarm ON Warning OFF Servo ready OFF Brake release OFF	Power reinput Reset signal (RST) input

[Tab. 6 - 2 (h)] Alarm list 8/9

Name ----- Display	Contents	Motion and output signal status	Way to release
SQB (Sequence control section) Alarm ----- <div style="border: 1px solid black; padding: 5px; width: fit-content;"> A L M .   S Q B  E R R . </div>	Access from SQB has been lost for 10 sec. at power ON, and 1 sec. in normal condition. Self-diagnostic or Forced jog mode is changed.	Motor in torq. free Alarm ON Warning OFF Servo ready OFF Brake release OFF	Power reinput
Remote sequ.control IC fault ----- <div style="border: 1px solid black; padding: 5px; width: fit-content;"> A L M .  N E T I C E R </div>	IC part to control communication of Remote sequence control is broken.	Motor in torq. free Alarm ON Warning OFF Servo ready OFF	Repair it by our service sec. .
Remote sequ.cont.commun.error ----- <div style="border: 1px solid black; padding: 5px; width: fit-content;"> A L M .  N E T E R R . </div>	Communication of Remote sequence control can not be used. It occurs when power of a controller using Sequence control is turned OFF first.	Motor in torq. free Alarm ON Warning OFF Servo ready OFF	Reinput power to whole system where Sequence control is remotely connected.
C P U fault ----- <div style="border: 1px solid black; padding: 5px; width: fit-content;"> A L M .  C P U R A M </div> <div style="border: 1px solid black; padding: 5px; width: fit-content;"> A L M .  E X R A M </div> <div style="border: 1px solid black; padding: 5px; width: fit-content;"> A L M .  D S P B O O T </div> <div style="border: 1px solid black; padding: 5px; width: fit-content;"> A L M .  D S P B O O T 1 </div> <div style="border: 1px solid black; padding: 5px; width: fit-content;"> A L M .  D S P P A R A </div>	Unit is out of order.	Motor in torq. free Alarm flashes Warning OFF Servo ready OFF Brake release OFF	Power reinput Replace or repair the unit by us.
C P U fault Front LED is lit. HALT 	Due to fault of CPU, memory (ROM, RAM), etc. Watch dog timer alarm is activated.	Motor in torq. free Alarm ON Warning OFF Servo ready OFF Brake release OFF	Power reinput Replace or repair the unit by us.



[Tab. 6 - 2 (i)] Alarm list 9/9

6 - 2 - 2 Warning list

Name ----- Display	Contents	Motion and output signal status	Way to release
Over load warning WNG . P OVER . LOAD	If current running conditions are continued, Over-load error will occur.	Current motion continues. Alarm OFF Warning ON Servo ready ON Brake release ON	Delete cause of Over-load.
Deviation error warning WNG . P VARI . OVER	Position deviation exceeds set of [P208 : Deviation error detection pulse] . Applied when 『Continuous motion』 is selected by [P209:Motion selection at Deviation abnormal].	Current motion continues. Alarm OFF Warning ON Servo ready ON Brake release ON	Delete cause of Deviation error. (Load increase, wrong setting of gain, Accel./Decel/time, etc.)
Main power under voltage detection warning WNG . P UNDRVOLT 2	Main circuit DC bus voltage becomes 180[370]V or less. In [], value of 400V type (In case of controller not combined with power source, this warning is detected.)	Motor in torq. free Alarm OFF Warning ON Servo ready OFF Brake release OFF	Recover main power source to normal voltage range.
Zero return incomplete auto. start warning告 WNG . P HOME . ERR .	Since Auto. run started in Zero return incomplete status, Start signal is ignored. When [P409 : Auto.run permit condition selection] is no condition, this is not detected.	Neglects Auto. start signal. Alarm OFF Warning ON Servo ready ON Brake release ON	Execute Zero return. (When mode other than Auto. mode is selected, Warning is OFF.)
Absolute encoder battery error warning WNG . P ABS . BATT .	External battery voltage for Absolute encoder data back up dropped. 『Detected, always.』 Applied when Absolute encoder is used.	Current motion continues. Alarm OFF Warning ON Servo ready ON Brake release ON	Replace external battery.
Absolute encoder preload incomplete warning WNG . P ABS . PRE . L	Preload and preset of Absolute encoder is not completed. Applied when Absolute encoder is used.	Current motion continues. Alarm OFF Warning ON Servo ready ON Brake release ON	Execute preload and preset program.
Remote sequence control commun. waiting warning WNG . P NET NORDY	Communication for Remote sequence control is not started. This occurs when controller for Remote sequence control is not functioning.	Current motion continues. Alarm OFF Warning ON Servo ready ON	Turn power of control ON for Remote Sequence control.

[Tab. 6 - 3] Warning list

6 - 2 - 3 Error list

Name ----- Display	Contents	Motion and output signal status	Way to release
Data input range error ----- 	Inputted parameter and data value is out of setting range.	In Edit mode, motor continues present motion. Output signal is not changed.	Release error by input of anykey and reset correct data.
Data setting value error ----- 	Computed results with plural associated values are out of setting range.	In Edit mode, motor continues present motion. Output signal is not changed.	Release error by input of anykey and reset correct data.
Duplicate operation error ----- 	Same address command is edited by LCD module and MDI, simultaneously.	In Edit mode, motor continues present motion. Output signal is not changed.	Release error by input of anykey and operate by only either one.

[Tab. 6 - 4] Error list

Appendix

Appendix - 1 Input and output signal list

[1] Input signal

Signal name	Code	Inp. Out.	Device No.		
			Serial communi.	Sequence control	Remote sequen- ce control
Reset	R S T	Inp.	X0000	M9144	Ymn00
Emergency stop	E M G *		X0001	M9145	Ymn01
Servo ON	SON(*)		X0002	M9146	Ymn02
Auto. start	P S T		X0003	M9147	Ymn03
Hold	H L D		X0004	M9148	Ymn04
Deviation clear	C L R		X0005	M9149	Ymn05
Forward 0.T	F O T *		X0006	M9150	Ymn06
Reverse 0.T	R O T *		X0007	M9151	Ymn07
Address set 1	S S 1		X0008	M9152	Ymn10
Address set 2	S S 2		X0009	M9153	Ymn11
Address set 3	S S 3		X000A	M9154	Ymn12
Address set 4	P S 4		X000B	M9155	Ymn13
Address set 5	P S 5		X000C	M9156	Ymn14
Address set 6	P S 6		X000D	M9157	Ymn15
Address set 7	P S 7		X000E	M9158	Ymn16
Address set 8	P S 8		X000F	M9159	Ymn17
Forward jog	F J		X0018	M9168	Ymn30
Reverse jog	R J		X0019	M9169	Ymn31
Speed override 1	O R 1		X001C	M9172	Ymn34
Speed override 2	O R 2		X001D	M9173	Ymn35
Speed override 3	O R 3		X001E	M9174	Ymn36
Speed override 4	O R 4		X001F	M9175	Ymn37
Mode select. 1	M D 1		X0020	M9176	Ymn40
Mode select. 2	M D 2		X0021	M9177	Ymn41
Jog speed selec.	J O S P		X0022	M9178	Ymn42
Torque limit	T L		X0023	M9179	Ymn43
Cmd. pls input inhibit	CIH(*)		X0024	M9180	Ymn44
M complete	M F I N		X0031	M9193	Ymn61
Block stop	B S T P		X0033	M9195	Ymn63
Block cancel	P C A N		X0034	M9196	Ymn64
Auto. start inh.	E P I H		X0035	M9197	Ymn65
Forced brake ON	B R O N		X0036	M9198	Ymn66
Spd gain select.	G S E L		X0037	M9199	Ymn67

- 1 Device No. column shows a device number of Remote control data area corresponding to individual signal.
- 2 And regardless to positive-true or negative-true logic, Remote control signal is "ON" to data "1" and "OFF" to data "0".
- 3 Mn of Ymn device is 2 digit numeral displayed by octal number for connection node ID No.

[2] output signal

Signal name	Code	Inp. Out.	Device No.		
			Serial communi.	Sequence control	Remote sequen- ce control
Alarm	ALM(*)	Out.	X0060	M9208	Xmn00
Warning	WNG(*)		X0061	M9209	Xmn01
Servo ready	R D Y		X0062	M9210	Xmn02
Speed zero	S Z		X0063	M9211	Xmn03
Position. complete	P N		X0064	M9212	Xmn04
Rough matching	P R F		X0065	M9213	Xmn05
Brake release	B R K		X0066	M9214	Xmn06
In Torque limit	L I M		X0067	M9215	Xmn07
Program end	P E N D		X0068	M9216	Xmn10
Auto. run ready	P R D Y		X0069	M9217	Xmn11
In Manual run	M M O D		X006A	M9218	Xmn12
In Zero return run	H M O D		X006B	M9219	Xmn13
In Auto. run	A M O D		X006C	M9220	Xmn14
In Pulse train run	P M O D		X006D	M9221	Xmn15
In Remote control	R M O D		X006E	M9222	Xmn16
General output 1	O U T 1		X0070	M9224	Xmn20
General output 2	O U T 2		X0071	M9225	Xmn21
General output 3	O U T 3		X0072	M9226	Xmn22
General output 4	O U T 4		X0073	M9227	Xmn23
General output 5	O U T 5		X0074	M9228	Xmn24
General output 6	O U T 6		X0075	M9229	Xmn25
General output 7	O U T 7		X0076	M9230	Xmn26
General output 8	O U T 8		X0077	M9231	Xmn27
Soft.lim. switch A	S L S A		X007E	M9238	Xmn36
Soft.lim. switch B	S L S B		X007F	M9239	Xmn37
M output 01	M O 1		X0080	M9240	Xmn40
M output 02	M O 2		X0081	M9241	Xmn41
M output 04	M O 4		X0082	M9242	Xmn42
M output 08	M O 8	X0083	M9243	Xmn43	
M output 10	M 1 0	X0084	M9244	Xmn44	
M output 20	M 2 0	X0085	M9245	Xmn45	
M output 40	M 4 0	X0086	M9246	Xmn46	
M output 80	M 8 0	X0087	M9247	Xmn47	
M strobe	M S T B	X008E	M9254	Xmn56	

- 1 Device No. column shows a device number of Remote control data area corresponding to individual signal.
- 2 And regardless to positive-true or negative-true logic, Remote control signal is "ON" to data "1" and "OFF" to data "0".
- 3 Mn of Xmn device is 2 digit numeral displayed by octal number for connection node ID No.

Appendix - 2 Applicable Motor List

【NCS - FI 200V system controller applicable motor selection list】

Controller capacity	P O O O set value	Applicable motor			Peak torque
		Motor type	Rate out.	Rated speed	
NCS - FI**M* - 401 Capacity : 0.4 kw In.voltage : 200V	211	NA30-13F-15	0.2 Kw	1500 rpm	300 %
	212	NA30-25F-15	0.4 Kw	1500 rpm	300 %
NCS - FI**M* - 801 Capacity : 0.8 kw In.voltage : 200V	221	NA100-20F	0.6 Kw	3000 rpm	300 %
	222	NA100-40F	0.8 Kw	2000 rpm	300 %
	223	NA100-75F-10	0.8 Kw	1000 rpm	300 %
	224	NA30-50F-15	0.8 Kw	1500 rpm	300 %
NCS - FI**M* - 122 Capacity : 1.5 kw In.voltage : 200V	231	NA100-75F	1.5 Kw	2000 rpm	300 %
	232	NA100-110F-10	1.2 Kw	1000 rpm	200 %
NCS - FI**M* - 242 Capacity : 2.2 kw In.voltage : 200V	241	NA100-110F	2.2 Kw	2000 rpm	300 %
	242	NA100-180F-10	1.9 Kw	1000 rpm	300 %
	243	NA30-110F-15	1.6 Kw	1500 rpm	300 %
NCS - FI**M* - 402 Capacity : 3.7 kw In.voltage : 200V	251	NA100-180F	3.7 Kw	2000 rpm	200 %
	252	NA100-270F-10	2.8 Kw	1000 rpm	300 %
	253	NA100-370F-10	3.7 Kw	1000 rpm	200 %
	254	NA30-180F-15	2.8 Kw	1500 rpm	300 %
NCS - FI**M* - 752 Capacity : 7.5 kw In.voltage : 200V	011	NA100-180F	3.7 Kw	2000 rpm	300 %
	012	NA100-270F	5.5 Kw	2000 rpm	200 %
	013	NA100-370AF	7.5 Kw	2000 rpm	200 %
	014	NA100-370F-10	3.7 Kw	1000 rpm	300 %
	015	NA100-550F-10	5.5 Kw	1000 rpm	200 %
	016	NA100-750F-10	7.5 Kw	1000 rpm	200 %
NCS - FI**M* - 113 Capacity : 11 kw In.voltage : 200V	023	NA100-270F	5.5 Kw	2000 rpm	300 %
	024	NA100-550F-10	5.5 Kw	1000 rpm	300 %
	025	NA100-750F-10	7.5 Kw	1000 rpm	290 %
	021	NA100-550AF	11 kw	2000 rpm	200 %
	022	NA100-1100F-10	11 kw	1000 rpm	200 %
NCS - FI**M* - 153 Capacity : 15 kw In.voltage : 200V	034	NA100-370F	7.5 Kw	2000 rpm	300 %
	031	NA100-750AF	15 kw	2000 rpm	200 %
	032	NA20-1500-10	15 kw	1000 rpm	200 %
	033	NA100-550F	11 kw	2000 rpm	300 %
NCS - FI**M* - 223 Capacity : 22 kw In.voltage : 200V	041	NA100-1100AF	22 kw	2000 rpm	200 %
	042	NA20-2200-10	22 kw	1000 rpm	200 %
	043	NA100-750F	15 kw	2000 rpm	290 %
NCS - FI**M* - 303 Capacity : 30 kw In.voltage : 200V	051	NA20-1500	30 kw	2000 rpm	200 %
	052	NA20-2700-10	30 kw	1000 rpm	200 %
	053	NA100-1100F	22 kw	2000 rpm	300 %
NCS - FI**M* - 373 Capacity : 37 kw In.voltage : 200V	061	NA20-1800	37 kw	2000 rpm	200 %
	062	NA20-3700-10	37 kw	1000 rpm	190 %

【NCS - FI 400V system controller applicable motor selection list】

Controller capacity	P 0 0 0 set value	Applicable motor			Peak torque
		Motor type	Rate out.	Rated speed	
NCS - FI**H* - 113 Capacity : 11kw In.voltage : 400V	121	NA100-550F-20H	11 kw	2000 rpm	200 %
	122	NA100-1100F-10H	11 kw	1000 rpm	200 %
	123	NA100-550F-20H	11 kw	2000 rpm	300 %
NCS - FI**H* - 153 Capacity : 15kw In.voltage : 400V	131	NA100-750F-20H	15 kw	2000 rpm	200 %
	132	NA20-1500-10H	15 kw	1000 rpm	200 %
NCS - FI**H* - 223 Capacity : 22kw In.voltage : 400V	141	NA100-1100F-20H	22 kw	2000 rpm	200 %
	142	NA20-2200-10H	22 kw	1000 rpm	200 %
	143	NA100-750F-20H	15 kw	2000 rpm	300 %
NCS - FI**H* - 303 Capacity : 30kw In.voltage : 400V	151	NA20-1500-20H	30 kw	2000 rpm	200 %
	152	NA20-2700-10H	30 kw	1000 rpm	200 %
	153	NA100-1100F-20H	22 kw	2000 rpm	300 %
NCS - FI**H* - 373 Capacity : 37kw In.voltage : 400V	161	NA20-1800-20H	37 kw	2000 rpm	200 %
	162	NA20-3700-10H	37 kw	1000 rpm	200 %

【NCS - FS 200V system controller applicable motor selection list】

Controller capacity	P 0 0 0 set value	Applicable motor			Peak torque
		Motor type	Rate out.	Rated speed	
NCS - FS**M* - 1 2 2 Capacity 1.2 kw In.voltage: 200V	5 5 1	NA720-122	1.2 kw	2000 rpm	300 %
NCS - FS**M* - 2 4 2 Capacity: 2.4 kw In.voltage: 200V	5 7 1	NA720-182	1.8 kw	2000 rpm	300 %
	5 7 2	NA720-242	2.4 kw	2000 rpm	300 %
NCS - FS**M* - 4 0 2 Capacity: 4.0 kw In.voltage: 200V	5 8 1	NA720-372	3.7 kw	2000 rpm	200 %
	5 8 2	NA720-402	4.0 kw	2000 rpm	200 %
NCS - FS**M* - 7 5 2 Capacity: 7.5 kw In.voltage: 200V	7 0 1	NA720-372	3.7 kw	2000 rpm	300 %
	7 0 2	NA720-402	4.0 kw	2000 rpm	300 %
	7 0 3	NA720-552	5.5 kw	2000 rpm	200 %
	7 0 4	NA720-752	7.5 kw	2000 rpm	200 %
NCS - FS**M* - 1 1 3 Capacity: 1.1 kw In.voltage: 200V	7 1 1	NA720-552	5.5 kw	2000 rpm	300 %
	7 1 2	NA720-113	1.1 kw	2000 rpm	200 %
NCS - FS**M* - 1 5 3 Capacity: 1.5 kw In.voltage: 200V	7 2 1	NA720-752	7.5 kw	2000 rpm	300 %
	7 2 2	NA720-153	1.5 kw	2000 rpm	200 %
NCS - FS**M* - 2 2 3 Capacity: 2.2 kw In.voltage: 200V	7 3 1	NA720-223	2.2 kw	2000 rpm	200 %